

Vérin compact magnétique Série 32

Simple et double effet, anti-rotation
Ø20, 25, 32, 40, 50, 63, 80, 100.



VÉRINS SÉRIE 32

- » Compact
- » Nombreux diamètres
- » ISO 21287

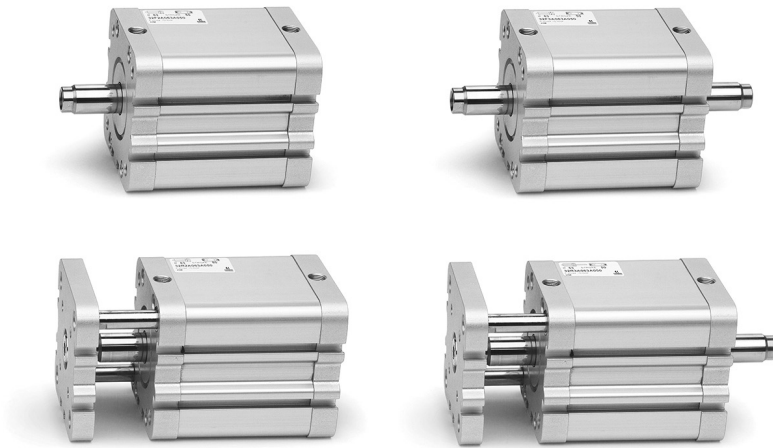

Les dimensions compactes de cette série permettent une utilisation dans des espaces restreints.
La Série 32, conforme à la norme ISO 21287 offre l'avantage de pouvoir être montée avec les accessoires des vérins DIN/ISO 6431 - VDMA 24562 (Série 60-61).

CARACTERISTIQUES GENERALES

Type de construction	compact profilé
Fonctionnement	simple et double effet, magnétique
Matériaux	tube et fonds AL anodisé, tige inox AISI 303 roulée, piston AL, joints de tige et de piston PU ou FKM (140°C)
Type de fixation	fond, bride, pieds, charnière
Course min-max (1)	Série 32F, 32M, 32R Ø20-25 = 5 à 300 mm Série 32F, 32M, 32R Ø32-40-50-63 = 5 à 400 mm Série 32F, 32M, 32R Ø80-100 = 5 à 500 mm
Température de fonctionnement	0 à 80°C (-20 °C avec air sec)
Pression de service	1 à 10 bar (double effet) 2 à 10 bar (simple effet)
Fluide	air filtré, sans lubrification ; En cas d'utilisation avec air lubrifié, il est conseillé d'utiliser de l'huile ISO VG32 et de ne jamais interrompre la lubrification.
Vitesse	10 à 1000 mm/sec (sans charge)

(1) = la course mini pour l'utilisation de capteurs magnétiques est de 10 mm.

TABLEAU DES COURSES STANDARDS DES VERINS SERIE 32

✕ = anti-rotation; ● = double effet mâle/femelle
■ = simple effet ressort av/ar - mâle/femelle

COURSES STANDARD										
Ø	5	10	15	20	25	30	40	50	60	80
20	✕ ● ■	✕ ● ■	✕ ● ■	✕ ● ■	✕ ● ■	✕ ●	✕ ●	✕ ●		
25	✕ ● ■	✕ ● ■	✕ ● ■	✕ ● ■	✕ ● ■	✕ ●	✕ ●	✕ ●		
32	✕ ● ■	✕ ● ■	✕ ● ■	✕ ● ■	✕ ● ■	✕ ●	✕ ●	✕ ●	✕ ●	✕ ●
40	✕ ● ■	✕ ● ■	✕ ● ■	✕ ● ■	✕ ● ■	✕ ●	✕ ●	✕ ●	✕ ●	✕ ●
50		✕ ● ■	✕ ● ■	✕ ● ■	✕ ● ■	✕ ●	✕ ●	✕ ●	✕ ●	✕ ●
63		✕ ● ■	✕ ● ■	✕ ● ■	✕ ● ■	✕ ●	✕ ●	✕ ●	✕ ●	✕ ●
80		✕ ● ■	✕ ● ■	✕ ● ■	✕ ● ■	✕ ●	✕ ●	✕ ●	✕ ●	✕ ●
100		✕ ● ■	✕ ● ■	✕ ● ■	✕ ● ■	✕ ●	✕ ●	✕ ●	✕ ●	✕ ●

VÉRINS SÉRIE 32

CODIFICATION DES VERINS SERIE 32

32	M	2	A	032	A	050	
32	SERIE						
M	VERSION : M = tige filetée, montée avec écrou de tige Mod. U F = tige taraudée R = anti-rotation avec bride (Double effet)						
2	FONCTIONNEMENT : 1 = simplet effet (ressort avant) 2 = double effet 3 = double effet (tige traversante) 4 = simple effet (ressort arrière)			SYMBOLES PNEUMATIQUES CS06 CD08 CD12 CS08			
A	MATERIAUX : A = Fonds, piston et tube aluminium anodisé - Joints de nez et de piston PU						
032	ALESAGE : 020 = 20 mm 025 = 25 mm 032 = 32 mm 040 = 40 mm 050 = 50 mm 063 = 63 mm 080 = 80 mm 100 = 100 mm						
A	ACCESSOIRES : A = Standard						
050	COURSE : (Voir tableau)						
	= standard S = Spécial V = Joint de tige FKM W = tous joints FKM (140°), non magnétique						

SYMBOLES PNEUMATIQUES

Les symboles pneumatiques indiqués dans la CODIFICATION sont représentés ci-dessous.

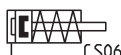
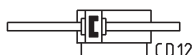

ACCESSOIRES POUR LA SERIE 32

VÉRINS SÉRIE 32



Chape à rotule de tige Mod. GY



Ecroû de tige Mod. U



Axe Mod. S

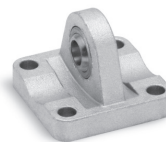

Charnière sphérique Mod. R

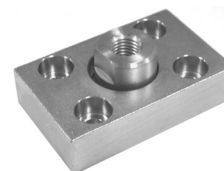

Bride de compensation Mod. GKF



Chape sphérique de tige Mod. GA

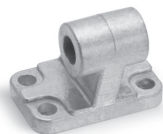

Charnière mâle à 90° Mod. ZC

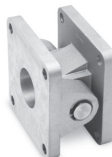

Charnière combinée Mod. C+L+S

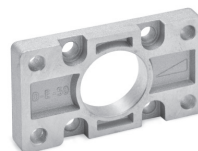

Bride avant/arrière Mod. D-E



Chape de compensation de tige Mod. GK



Contre-charnière Mod. I



Jeu de pieds Mod. B

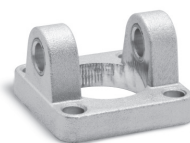

Charnière avant femelle Mod. H et C-H

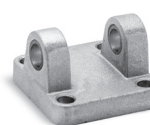

Charnière arrière femelle Mod. C et C-H

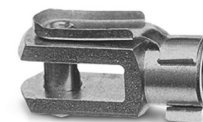

Chape de tige Mod. G

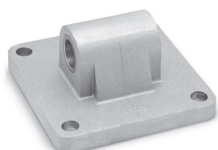

Charnière arrière mâle Mod. L



Les accessoires sont livrés non-montés sur les vérins

DIAGRAMME DES CHARGES ADMISSIBLES

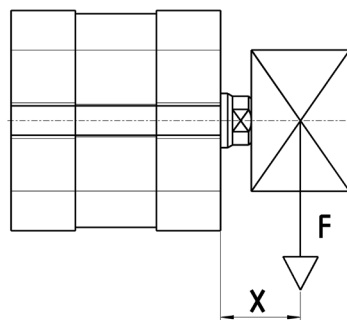
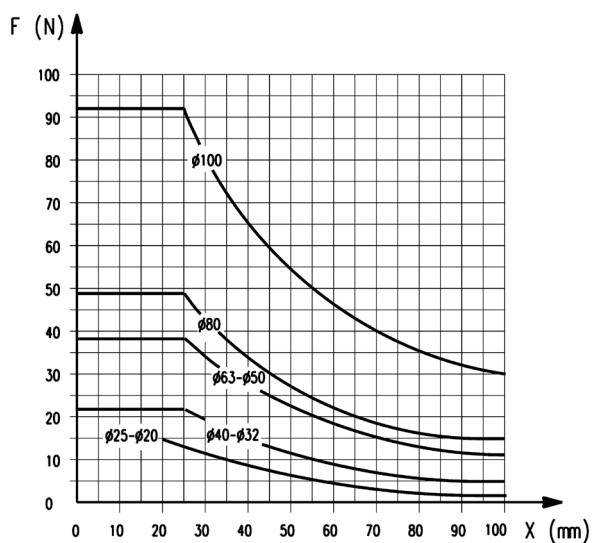

Standard
Charge transversale (F) en fonction de la projection (X)

DIAGRAMME DES CHARGES ADMISSIBLES

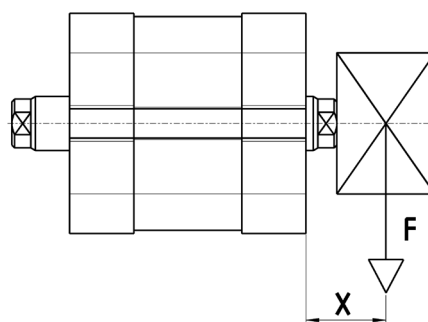
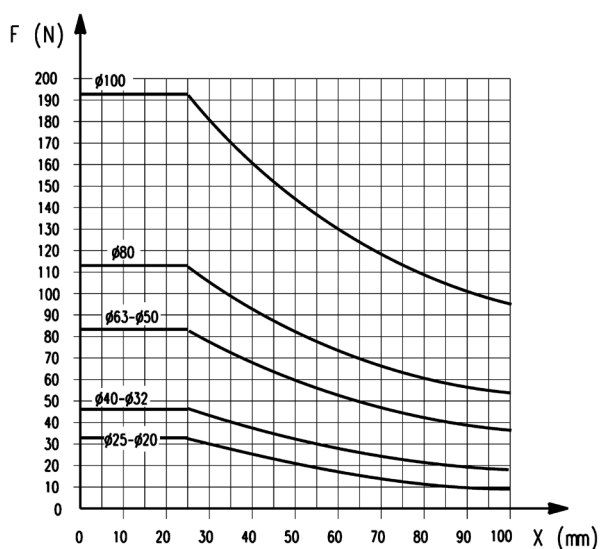

Tige traversante.
Charge transversale (F) en fonction de la projection (X)

VÉRINS SÉRIE 32

DIAGRAMME DES CHARGES ADMISSIBLES

VÉRINS SÉRIE 32

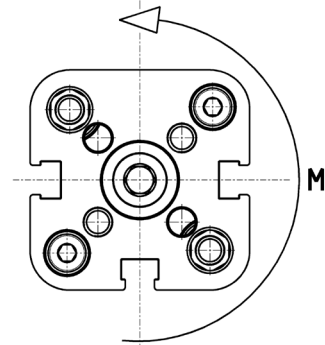
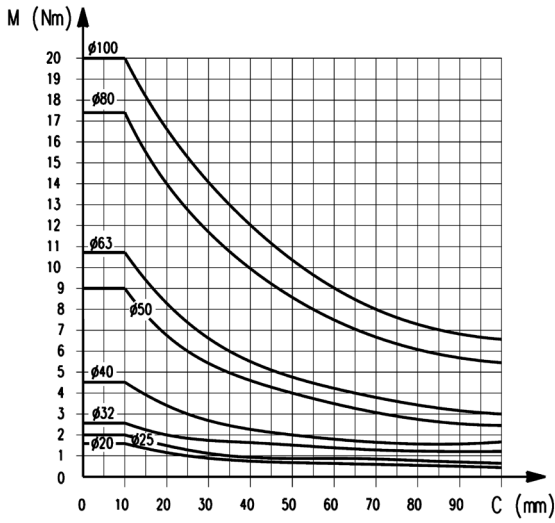

Il est possible de réaliser la totalité des courses indiquées dans les caractéristiques générales en absence de forces radiales et de moments de torsion.

En présence de forces radiales, respecter la course maxi du baricentre.

En présence de moments de torsion, respecter la course maxi comme indiqué dans les diagrammes..

Moment de torsion (M) en fonction de la course (C).

DIAGRAMME DES CHARGES ADMISSIBLES

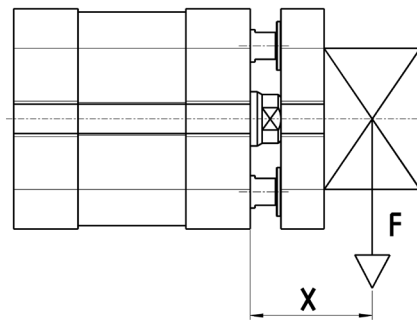
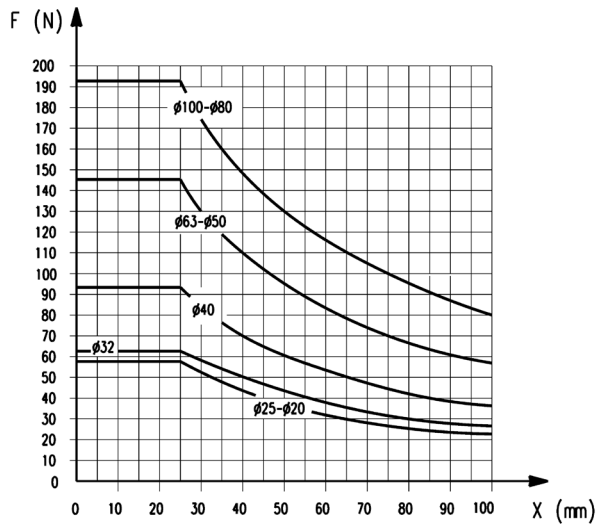

Anti-rotation.
Charge transversale (F) en fonction de la projection (X)

TABEAU DES CHARGES ADMISSIBLES

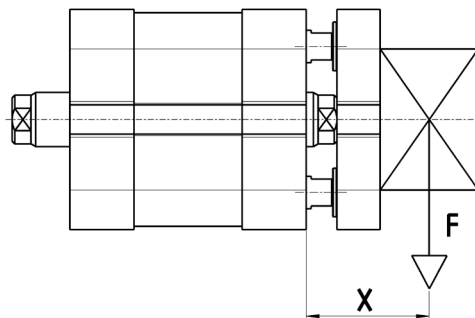
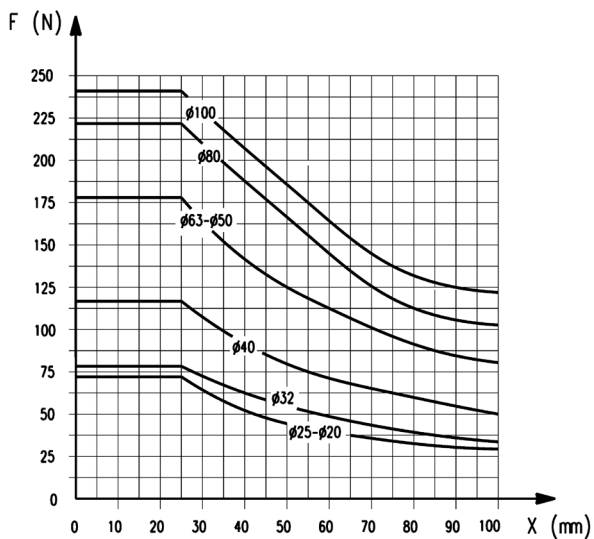

VÉRINS SÉRIE 32

tige traversante anti-rotation.
Charge transversale (F) en fonction de la projection (X)

EXEMPLES DE FIXATION

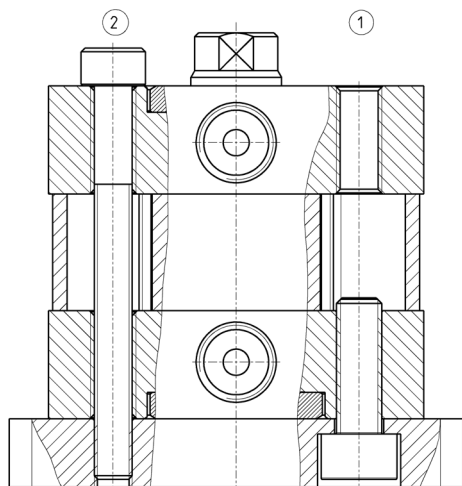

Exemple de fixation pour les vérins Ø32, 40, 50, 63, 80, 100.
1 = Fixation par le bas
2 = Fixation par le haut

N.B. Pour une fixation par le haut avec vis traversantes, utiliser des vis amagnétiques.

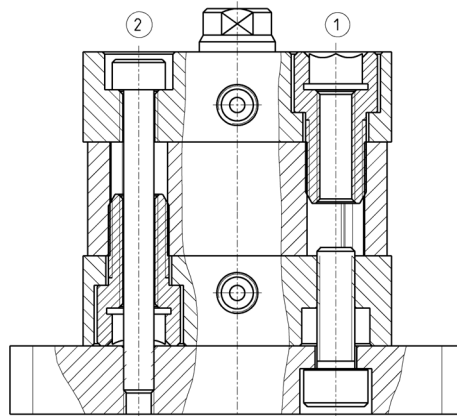

Exemple de fixation pour les vérins Ø20, 25.
1 = Fixation par le bas
2 = Fixation par le haut

N.B. Pour une fixation par le haut avec vis traversantes, utiliser des vis amagnétiques.

Vérins compacts magnétiques Mod. 32F et 32M



+ signifie ajouter la course
1 = rainure pour capteur

VÉRINS SÉRIE 32

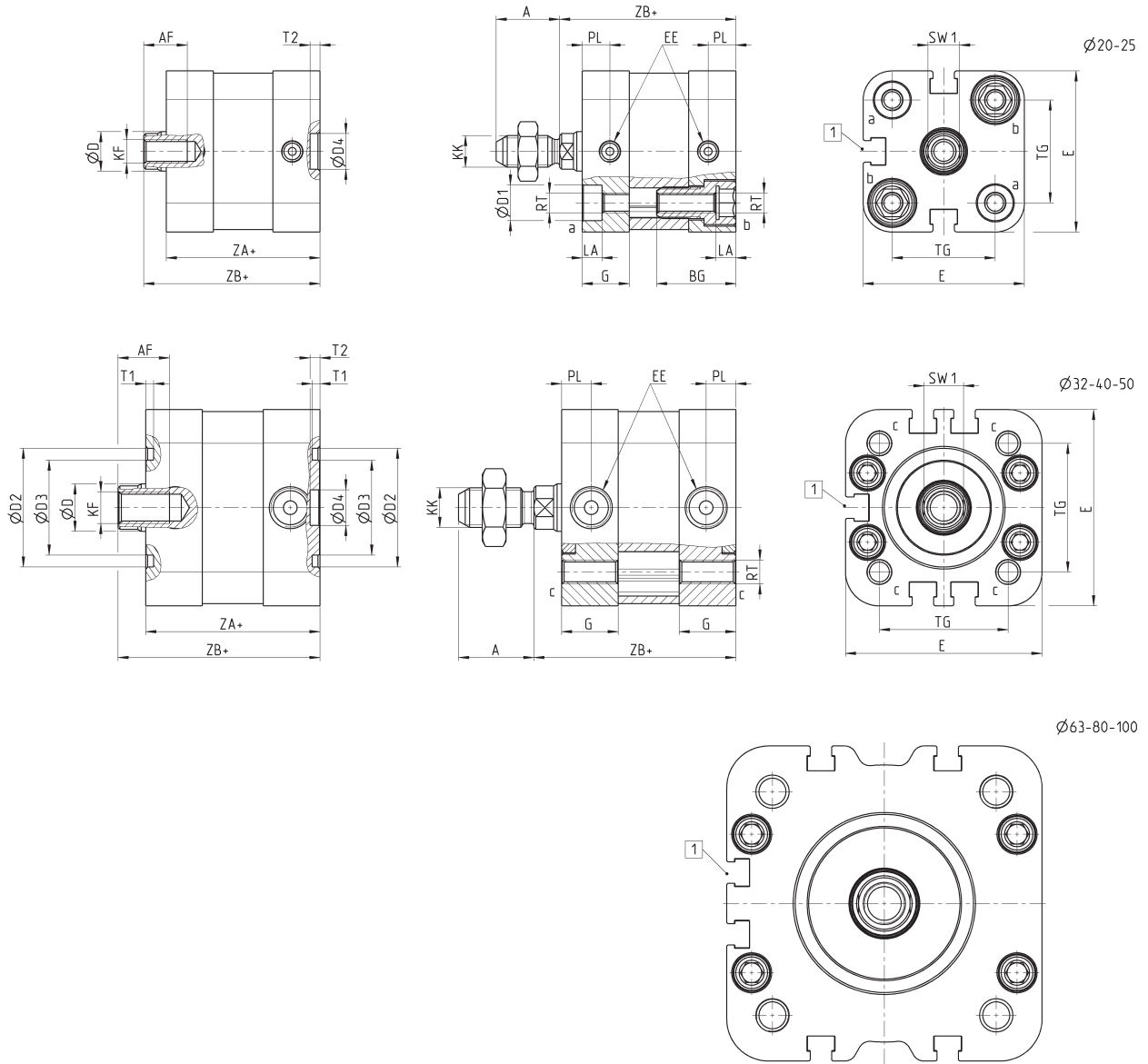

DIMENSIONS																						
Ø	A	AF	BG	G	ØD	D1	ØD2	ØD3	ØD4	E	EE	KF	KK	LA	PL	RT	SW1	T1	T2	TG	ZA	ZB
20	16	11	20	10,9	10	9	-	-	9	35,8	M5	M6	M8X1,25	5	6,5	M5	8	-	2,5	22	36,8	42,5
25	16	11	20	11,9	10	9	-	-	9	40,7	M5	M6	M8X1,25	5	7	M5	8	-	2,5	26	38,8	44,5
32	19	13	-	14,3	12	-	30	24	9	49,6	G1/8	M8	M10X1,25	-	7,6	M6	10	2	2,5	32,5	44	51
40	19	13	-	14,3	12	-	35	29	9	57	G1/8	M8	M10X1,25	-	7,6	M6	10	2	2,5	38	45	52
50	22	16	-	14,3	16	-	40	34	12	69,6	G1/8	M10	M12X1,25	-	7,6	M8	13	2	3	46,5	45	53
63	22	16	-	14	16	-	45	39	12	79,6	G1/8	M10	M12X1,25	-	7,6	M8	13	2	3	56,5	49	57
80	28	20	-	14,8	20	-	45	39	12	95,6	G1/8	M12	M16X1,5	-	7,7	M10	17	2	3	72	54	63,5
100	28	20	-	17,8	25	-	55	49	12	115,6	G1/8	M12	M16X1,5	-	8	M10	22	2	3	89	66,8	76,5

Vérins compacts magnétiques Mod. 32F3 et 32M3



+ signifie ajouter la course
++ signifie ajouter 2 fois la course
1 = rainure pour capteur

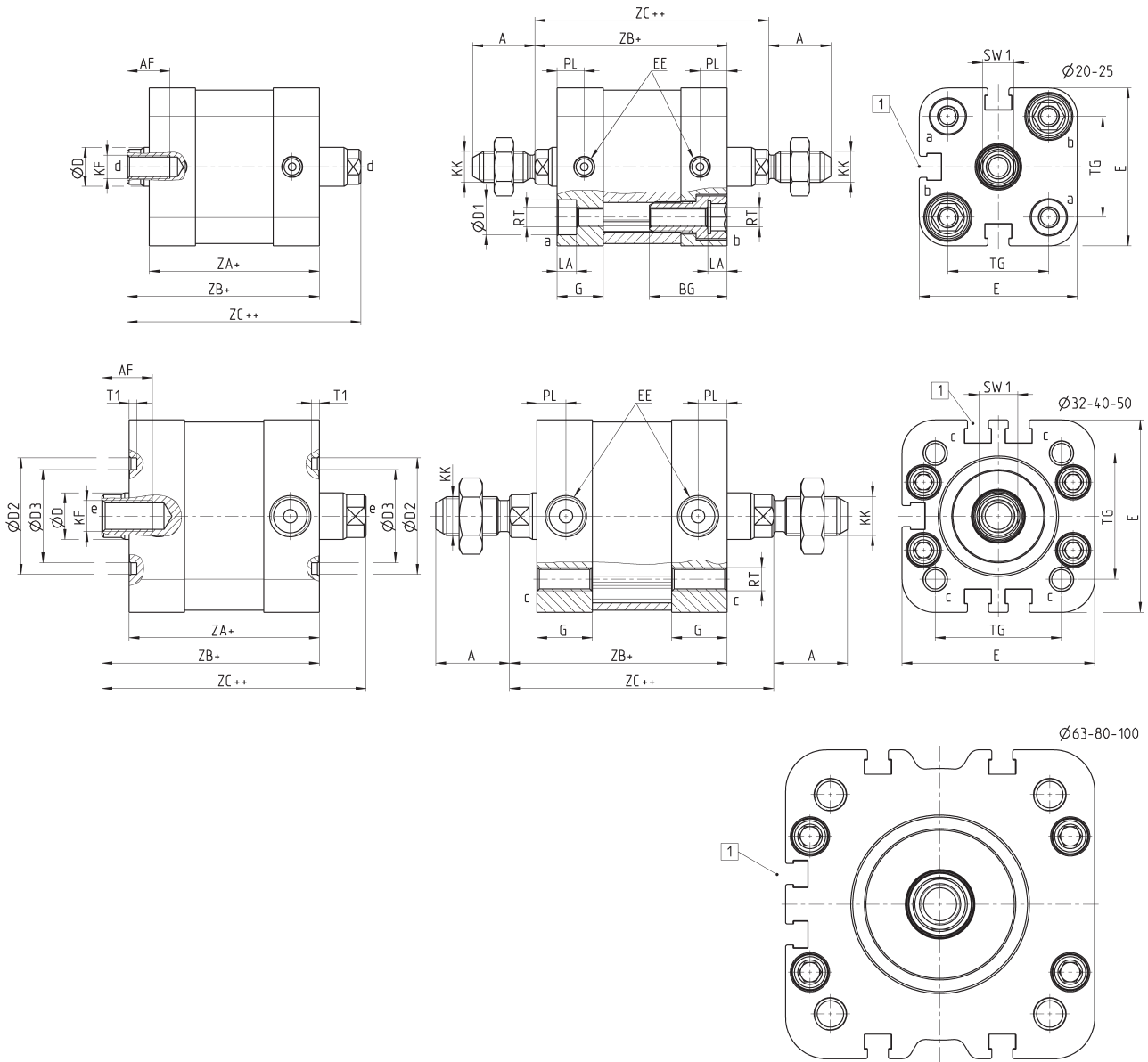

VÉRINS SÉRIE 32

DIMENSIONS																					
Ø	A	AF	BG	G	ØD	ØD1	ØD2	ØD3	E	EE	KF	KK	LA	PL	RT	SW1	T1	TG	ZA	ZB	ZC
20	16	11	20	10,9	10	9	-	-	35,8	M5	M6	M8X1,25	5	6,5	M5	8	-	22	36,8	42,5	48,2
25	16	11	20	11,9	10	9	-	-	40,7	M5	M6	M8X1,25	5	7	M5	8	-	26	38,8	44,5	50,2
32	19	13	-	14,3	12	-	30	24	49,6	G1/8	M8	M10X1,25	-	7,6	M6	10	2	32,5	44	51	58
40	19	13	-	14,3	12	-	35	29	57	G1/8	M8	M10X1,25	-	7,6	M6	10	2	38	45	52	59
50	22	16	-	14,3	16	-	40	34	69,6	G1/8	M10	M12X1,25	-	7,6	M8	13	2	46,5	45	53	61
63	22	16	-	14	16	-	45	39	79,6	G1/8	M10	M12X1,25	-	7,6	M8	13	2	56,5	49	57	65
80	28	20	-	14,8	20	-	45	39	95,6	G1/8	M12	M16X1,5	-	7,7	M10	17	2	72	54	63,5	73
100	28	20	-	17,8	25	-	55	49	115,6	G1/8	M12	M16X1,5	-	8	M10	22	2	89	66,8	76,5	86,2

Vérins compacts magnétiques Mod. 32R



+ signifie ajouter la course
++ signifie ajouter 2 fois la course
1 = rainure pour capteur

VÉRINS SÉRIE 32

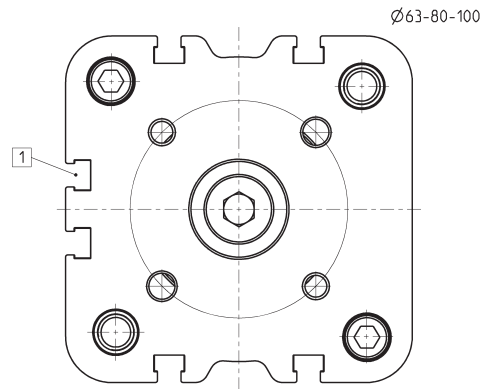
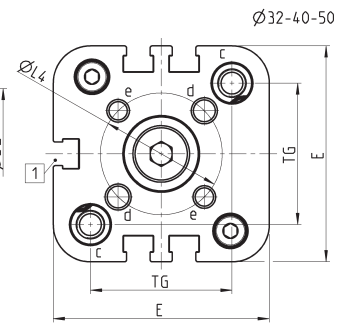
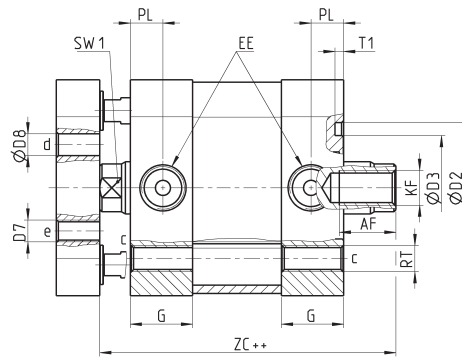
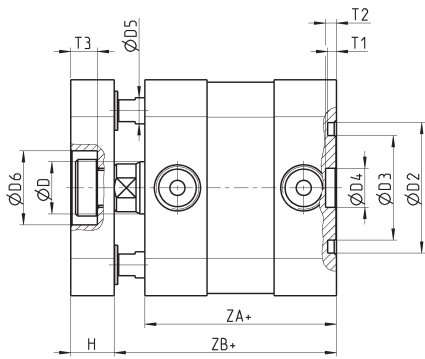
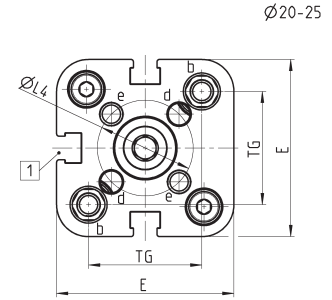
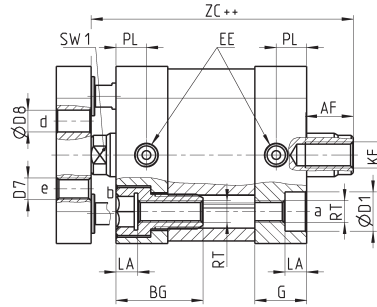
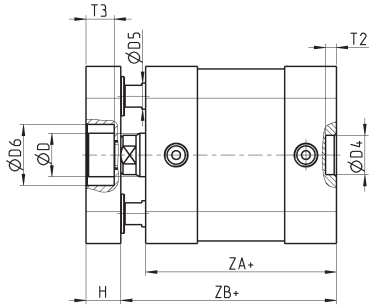

DIMENSIONS																												
Ø	AF	BG	G	ØD	ØD1	ØD2	ØD3	ØD4	ØD5	ØD6	D7	ØD8	E	EE	H	KF	LA	ØL4	PL	RT	SW1	T1	T2	T3	TG	ZA	ZB	ZC
20	11	20	10.9	10	9	-	-	9	6	-	M4	4	35.8	M5	8	M6	5	17	6.5	M5	8	-	2.5	-	22	36.8	42.5	48.2
25	11	20	11.9	10	9	-	-	9	6	14	M5	5	40.7	M5	8	M6	5	22	7	M5	8	-	2.5	6.5	26	38.8	44.5	50.2
32	13	-	14.3	12	-	30	24	9	6	17	M5	5	49.6	G1/8	10	M8	-	28	7.6	M6	10	2	2.5	6	32.5	44	51	58
40	13	-	14.3	12	-	35	29	9	6	17	M5	5	57	G1/8	10	M8	-	33	7.6	M6	10	2	2.5	6	38	45	52	59
50	16	-	14.3	16	-	40	34	12	10	22	M6	6	69.6	G1/8	12	M10	-	42	7.6	M8	13	2	3	7	46.5	45	53	61
63	16	-	14	16	-	45	39	12	10	22	M6	6	79.6	G1/8	12	M10	-	50	7.6	M8	13	2	3	7	56.5	49	57	65
80	20	-	14.8	20	-	45	39	12	12	24	M8	8	95.6	G1/8	14	M12	-	65	7.7	M10	17	2	3	10.5	72	54	63.5	73
100	20	-	18	25	-	55	49	12	12	24	M10	10	115.6	G1/8	14	M12	-	80	8	M10	22	2	3	10.5	89	67	76.7	86.2

Jeu de pieds Mod. B

Matériau : acier zingué



Complet avec :
2 pieds
4 vis

+ signifie ajouter la course

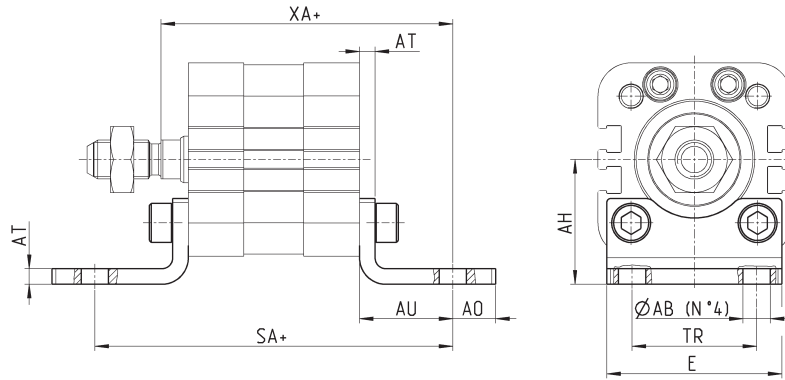

DIMENSIONS										
Mod.	Ø	ØAB	AH	AO	AU	AT	E	TR	SA	XA
B-32-20	20	6,5	27	9	16	4	35	22	68,8	58,5
B-31-25	25	6,5	29	9	16	4	39	26	70,8	60,5
B-41-32	32	7	32	11	24	4	45	32	92	75
B-41-40	40	10	36	15	28	4	53,5	36	101	80
B-41-50	50	10	45	15	32	4	62,5	45	109	85
B-41-63	63	10	50	15	32	5	73	50	113	89
B-41-80	80	12	63	20	41	6	92	63	136	104,5
B-41-100	100	14,5	71	25	41	6	108,5	71	148,8	117,5

VÉRINS SÉRIE 32

Charnière arrière femelle Mod. C et C-H

Matériau : aluminium

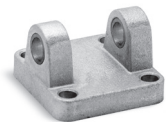

Complet avec :
1 charnière femelle
4 vis

+ signifie ajouter la course

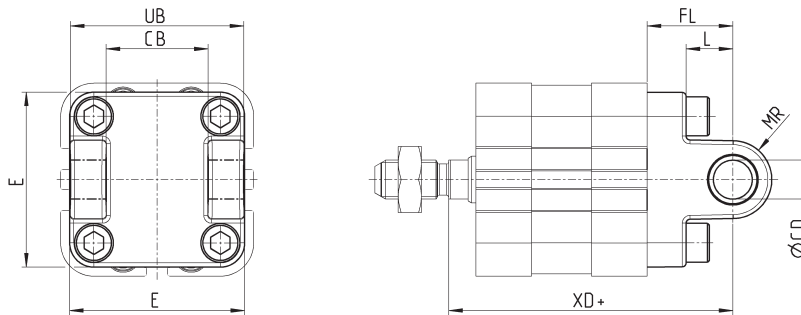

DIMENSIONS									
Mod.	Ø	ØCD	E	CB	UB	L	FL	MR	XD
C-41-32	32	10	45	26	45	12	22	10	73
C-41-40	40	12	53,5	28	52	15	25	12	77
C-41-50	50	12	62,5	32	60	15	27	13	80
C-H-41-63	63	16	73	40	70	20	32	17	89
C-H-41-80	80	16	92	50	90	24	36	17	99,5
C-H-41-100	100	20	108,5	60	110	29	41	21	117,5

Charnière avant femelle Mod. H et C-H

Matériau : aluminium

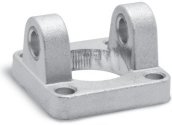

Complet avec :
1 charnière femelle
4 vis

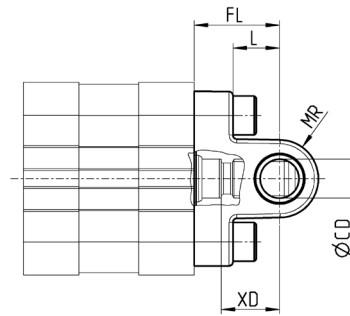
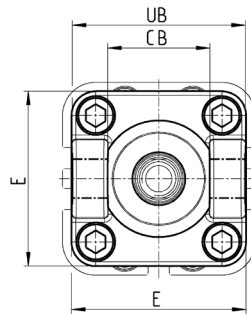

VÉRINS SÉRIE 32

DIMENSIONS									
Mod.	Ø	ØCD	E	CB	UB	L	FL	MR	XD
H-41-32	32	10	45	26	45	12	22	10	15
H-41-40	40	12	53,5	28	52	15	25	12	18
H-41-50	50	12	62,5	32	60	15	27	13	19
H-60-63	63	16	73	40	70	20	32	17	24
C-H-41-80	80	16	92	50	90	24	36	17	26,5
C-H-41-100	100	20	108,5	60	110	29	41	21	31,3

Bride avant/arrière Mod. D-E

Matériau : acier zingué Ø20-25, Aluminium Ø32-100.

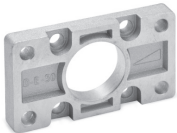

Complet avec :
1 Bride
4 Vis

+ signifie ajouter la course

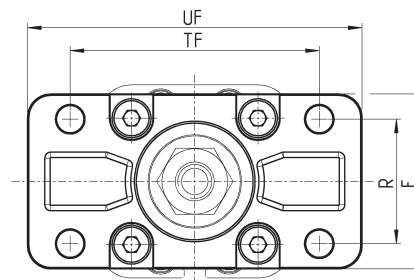
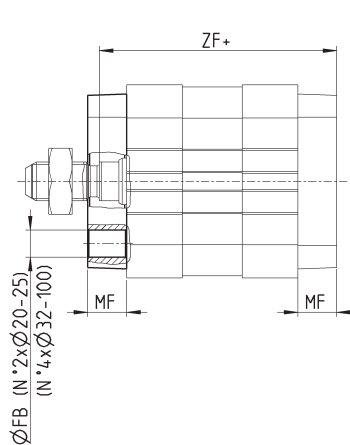

DIMENSIONS									
Mod.	Ø	ØFB	E	MF	R	TF	UF	ZF	
D-E-32-20	20	6,6	36	10	-	55	70	52,5	
D-E-32-25	25	6,6	40	10	-	60	76	54,5	
D-E-41-32	32	7	45	10	32	64	86	61	
D-E-41-40	40	9	52	10	36	72	88	62	
D-E-41-50	50	9	63	12	45	90	110	65	
D-E-41-63	63	9	73	12	50	100	116	69	
D-E-41-80	80	12	95	16	63	126	148	79,5	
D-E-41-100	100	14	115	16	75	150	176	92,5	

Charnière arrière mâle Mod. L

Matériau : aluminium

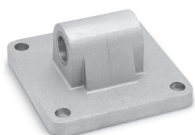

Complet avec :
1 charnière mâle
4 vis

+ signifie ajouter la course

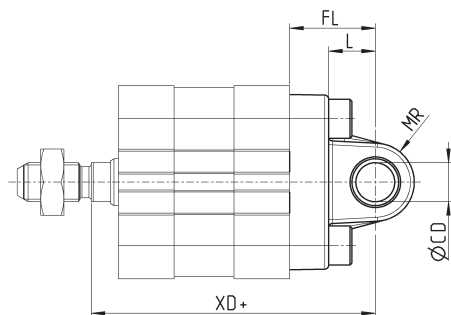
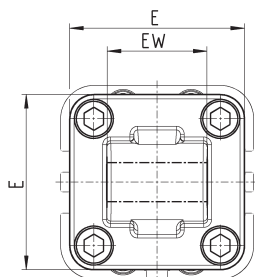

DIMENSIONS								
Mod.	Ø	ØCD	E	EW	L	FL	MR	XD
L-32-20	20	8	34	16	14	20	8	62,5
L-32-25	25	8	38	16	14	20	8	64,5
L-41-32	32	10	45	26	12	22	10	73
L-41-40	40	12	53,5	28	15	25	13	77
L-41-50	50	16	62,5	32	15	27	13	80
L-41-63	63	16	73	40	20	32	17	89
L-41-80	80	20	92	50	24	36	17	99,5
L-41-100	100	20	108,5	60	29	41	21	117,5

Charnière sphérique Mod. R*

Matériau : aluminium
* non selon norme ISO 15552

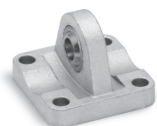

Complet avec :
1 charnière sphérique
4 vis

+ signifie ajouter la course

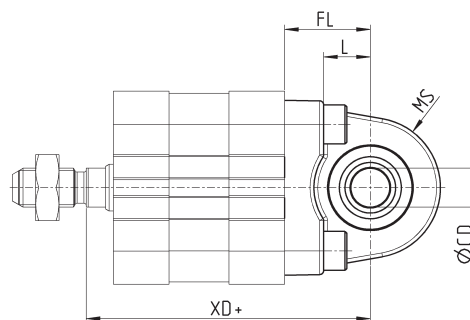
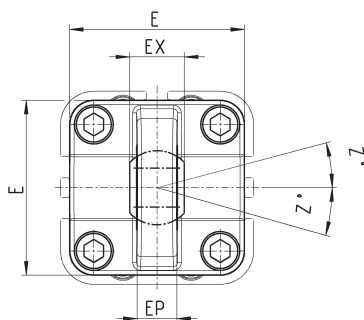

DIMENSIONS										
Mod.	Ø	ØCD	E	EX	EP	L	FL	MS	XD	Z°
R-41-32	32	10	45	14	10.5	12	22	18	73	4
R-41-40	40	12	53.5	16	12	15	25	18	77	4
R-41-50	50	12 *	62.5	16 *	12 *	15	27	21	80	4
R-41-63	63	16	73	21	15	20	32	23	89	4
R-41-80	80	16 *	92	21 *	15 *	24	36	28	99.5	4
R-41-100	100	20	108.5	25	18	29	41	30	117.5	4

Charnière combinée Mod. C+L+S

Matériau : aluminium

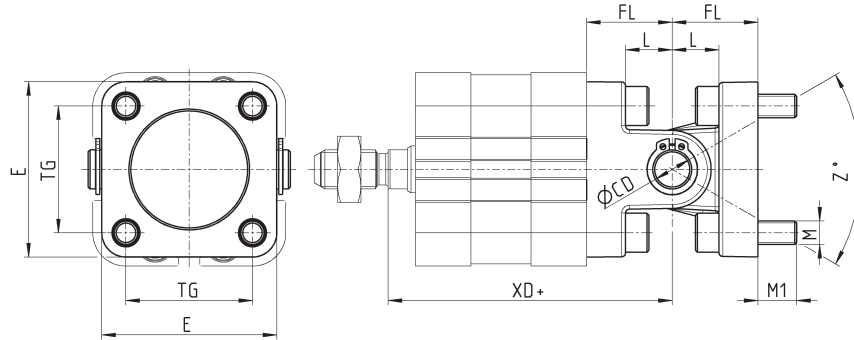

+ signifie ajouter la course

VÉRINS SÉRIE 32

DIMENSIONS										
Mod.	∅	∅CD	E	L	FL	M	M1	TG	XD+	Z° (max)
C+L+S	32	10	45	12	22	M6	10	32.5	73	30
C+L+S	40	12	53.5	15	25	M6	10	38	77	40
C+L+S	50	12	62.5	15	27	M8	13	46.5	80	25
C+L+S	63	16	73	20	32	M8	13	56.5	89	36
C+L+S	80	16	92	24	36	M10	16	72	99.5	34
C+L+S	100	20	108.5	29	41	M10	16	89	117.5	38

Charnière mâle à 90° Mod. ZC

Matériau : aluminium

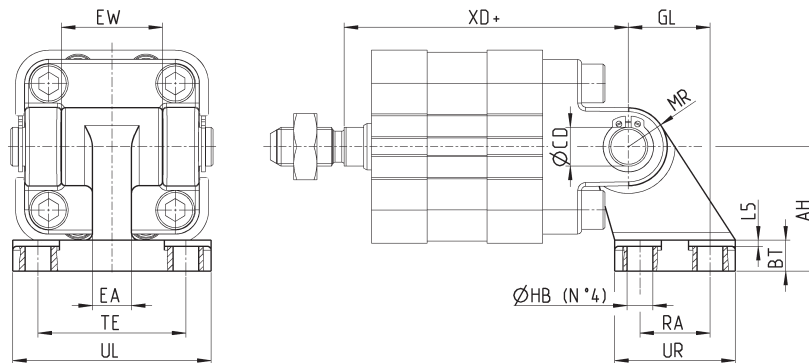
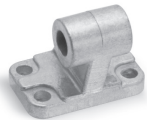

Complet avec :
1 charnière mâle

+ signifie ajouter la course

DIMENSIONS															
Mod.	∅	AH	BT	∅CD	EA	EW	GL	∅HB	L5	MR	RA	UL	UR	TE	XD
ZC-32	32	32	8	10	10	26	21	6,6	1,6	10	18	51	31	38	73
ZC-40	40	36	10	12	15	28	24	6,6	1,6	11	22	54	35	41	77
ZC-50	50	45	12	12	16	32	33	9	1,6	13	30	65	45	50	80
ZC-63	63	50	14	16	16	40	37	9	1,6	15	35	67	50	52	89
ZC-80	80	63	14	16	20	50	47	11	2,5	15	40	86	60	66	99,5
ZC-100	100	71	17	20	20	60	55	11	2,5	19	50	96	70	76	117,5

Charnière combinée Mod. I

Matériau : acier zingué



Complet avec :
1 charnière femelle
1 axe
2 anneaux élastiques
+ signifie ajouter la course

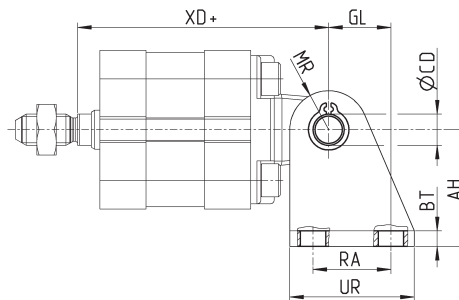
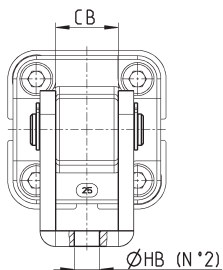

DIMENSIONS											
Mod.	∅	AT	BT	∅CD	CB	GL	∅HB	MR	RA	UR	XD
I-20-25	20	30	4	8	16,1	16	6,5	10	20	32	62,5
I-20-25	25	30	4	8	16,1	16	6,5	10	20	32	64,5

VÉRINS SÉRIE 32

Axe Mod. S



Complet avec :
1 axe inox
2 anneaux élastiques acier

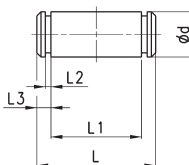

DIMENSIONS						
Mod.	∅	D	L	L1	L2	L3
S-32	32	10	52	46	1,1	3
S-40	40	12	59	53	1,1	3
S-50	50	12	67	61	1,1	3
S-63	63	16	77	71	1,1	3
S-80	80	16	97	91	1,1	3
S-100	100	20	121	111	1,3	5

Chape de tige Mod. G

Matériau : acier zingué
iso 8140

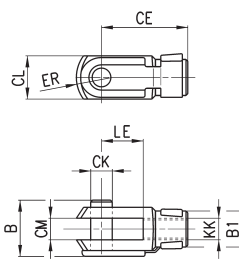

DIMENSIONS										
Mod.	∅	∅ _{CK}	LE	CM	CL	ER	CE	KK	B	∅ _{B1}
G-20	20-25	8	16	8	16	10	32	M8X1,25	22	14
G-25-32	32-40	10	20	10	20	12	40	M10x1,25	26	18
G-40	50-63	12	24	12	24	14	48	M12x1,25	32	20
G-50-63	80-100	16	32	16	32	19	64	M16x1,5	40	26

Chape à rotule de tige Mod. GY

Matériau : acier zingué et zama

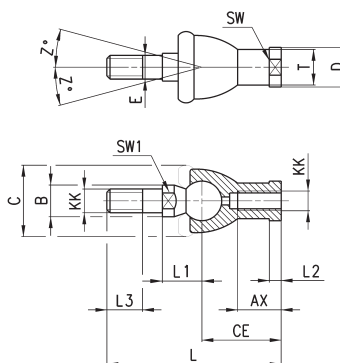

DIMENSIONS																
Mod.	∅	KK	L	CE	L2	AX	SW	SW1	L1	L3	∅ _T	∅ _D	E	∅ _B	∅ _C	Z
GY-20	20-25	M8X1,25	65	32	5	16	14	10	16	12	12,5	13	6	10	20	15
GY-32	32-40	M10X1,25	74	35	6,5	18	17	11	19,5	15	15	19	10	14	28	15
GY-40	50-63	M12X1,25	84	40	6,5	20	19	17	21	17	17,5	22	12	19	32	15
GY-50-63	80-100	M16X1,5	112	50	8	27	22	19	27,5	23	22	27	16	22	40	11

Chape sphérique de tige Mod. GA



ISO 8139
Matériau : acier zingué

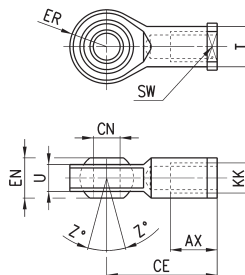

DIMENSIONS											
Mod.	Ø	øCN	U	EN	ER	AX	CE	KK	øT	Z	SW
GA-20	20-25	8	9	12	12	16	36	M8X1,25	12,5	6,5	14
GA-32	32-40	10	10,5	14	14	20	43	M10x1,25	15	6,5	17
GA-40	50-63	12	12	16	16	22	50	M12X1.25	17,5	6,5	19
GA-50-63	80-100	16	15	21	21	28	64	M16x1,5	22	7,5	22

Ecrou de tige Mod. U



ISO 4035
Matériau : acier zingué.

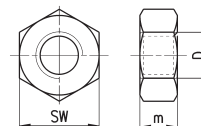

DIMENSIONS				
Mod.	Ø	D	M	SW
U-20	20-25	M8X1.25	5	13
U-25-32	32-40	M10X1,25	6	17
U-40	50-63	M12X1,25	7	19
U-50-63	80-100	M16X1,5	8	24

Entretoise de centrage Mod. TR



Complet avec :
1 anneaux de centrage en aluminium anodisé

Conçu pour, le centrage sur les fonds, des accessoires avants/arrières Mod. B, D-E, C, C-H, H, L et R ainsi que, pour le centrage du vérin sur un châssis.

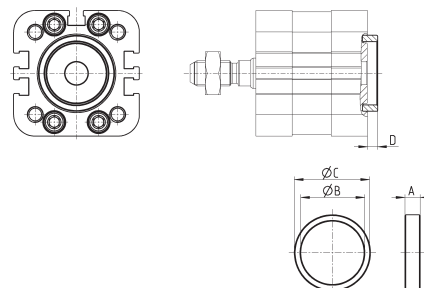

DIMENSIONS					
Mod.	Ø	A	øB	øC	D
TR-32-32	32	6	25	30	4
TR-32-40	40	6	30	35	4
TR-32-50	50	6	35	40	4
TR-32-63	63-80	7	40	45	5
TR-32-100	100	7	50	55	5

Plot de centrage Mod. TS-32-20

Matériau : aluminium anodisé
Conçu pour, le centrage sur le fond arrière, des accessoires Mod. L-32-20 et L-32-25 ainsi que, pour le centrage du vérin sur un châssis. N.B. : Prévu aussi pour un montage dans les trous "a" des fonds des vérins Ø20 et 25 mais aussi pour un montage dans le trou de centrage du fond arrière des vérins Ø32 et 40.

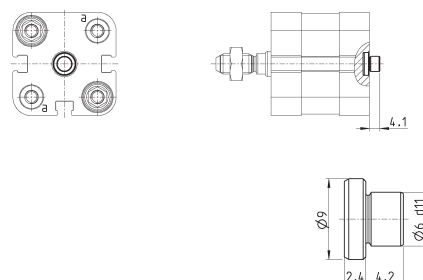

Mod.	TS-32-20
------	----------

Chape de compensation de tige Mod. GK



Seulement pour vérin version tige fileté

Matériau: acier zingué.

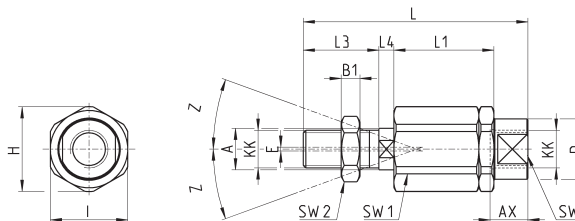

DIMENSIONS																	
Mod.	Ø	KK	L	L1	L3	L4	ØA	ØD	H	I	SW	SW1	SW2	B1	AX	Z	E
GK-20	20-25	M8x1,25	57	26	21	5	8	12,5	19	17	11	7	13	4	16	4	2
GK-25-32	32-40	M10x1,25	71,5	35	20	7,5	14	22	32	30	19	12	17	5	22	4	2
GK-40	50-63	M12x1,25	75,5	35	24	7,5	14	22	32	30	19	12	19	6	22	4	2
GK-50-63	80-100	M16x1,5	104	53	32	10	22	32	45	41	27	20	24	8	30	3	2

Bride de compensation Mod. GKF



Matériau: acier zingué.

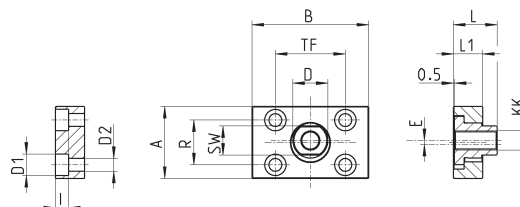

DIMENSIONS														
Mod.	Ø	KK	A	B	R	TF	L	L1	I	ØD	ØD1	ØD2	SW	E
GKF-20	20-25	M8x1,25	30	35	20	25	22,5	10	-	14	5,5	-	13	1,5
GKF-25-32	32-40	M10x1,25	37	60	23	36	22,5	15	6,8	18	11	6,6	15	2
GKF-40	50-63	M12x1,25	56	60	38	42	22,5	15	9	20	15	9	15	2,5
GKF-50-63	80-100	M16x1,5	80	80	58	58	26,5	15	10,5	25	18	11	22	2,5