

# Vérins course brève Séries QP et QPR

Série QP: simple et double effet, magnétique  
 Série QPR: anti-rotation, double effet magnétique  
 Ø12-16-20-25-32-40-50-63-80-100

VÉRINS COURSE BRÈVE SÉRIE QP ET QPR



Les vérins course brève Série QP et QPR sont disponibles en 10 diamètres différents allant de Ø12 à Ø100. Les dimensions compactes de cette série permettent une utilisation dans des espaces restreints. Grâce à leur forme particulière, ces vérins peuvent-être associés à une charnière arrière ou à un jeu de pieds.

Sur trois côtés, le corps profilé du vérin est pourvu de rainures pouvant recevoir des capteurs magnétiques de proximité. La version QPR ( avec guigade anti-rotation intégré ) permet une utilisation pour les opérations d'alimentation et de prélèvement de pièces dans des systèmes de manipulation.

## CARACTERISTIQUES GENERALES

<b>Type de construction</b>	Série QP : profilé compact Série QPR : profilé compact avec guide anti-rotation
<b>Fonctionnement</b>	Série QP : simple et double effet Série QPR : double effet
<b>Matériaux</b>	corps : aluminium anodisé tige : inox roulée joint de nez : PU joints de tige : PU (Ø 12 ÷ 25 mm) - NBR (Ø 32 ÷ 100 mm)
<b>Température de fonctionnement</b>	0 à 80°C ( -20 °C avec air sec )
<b>Type de fixation</b>	au moyen de vis ou d'accessoires
<b>Pression de service</b>	1 à 10 bar ( double effet ) 2 à 10 bar ( simple effet )
<b>Fluide</b>	air filtré, sans lubrification. En cas d'utilisation avec air lubrifié, il est conseillé d'utiliser de l'huile ISO VG32 et de ne jamais interrompre la lubrification.
<b>Course min-max</b>	Série QP : 1 à 150 mm (Ø 12 à 25) - 1 à 200 mm (Ø32 à 100) Série QPR: 1 à 50 mm (Ø12) - 1 à 75 mm (Ø16) - 1 à 100 mm (Ø20 à 100)
<b>Corse</b>	La course mini pour l'utilisation de capteurs est de 10 mm
<b>Alésages</b>	Ø12, 16, 20, 25, 32, 40, 50, 63, 80, 100

**TABLEAU DES COURSES STANDARDS DES VERINS COURSE BREVE SERIE QP ET QPR**

■ = Double effet    x = Simple effet    ● = Anti-rotation

COURSES STANDARD														
∅	5	10	15	20	25	30	35	40	45	50	60	75	80	100
12	■ x ●	■ x ●	■ x ●	■ x	■ x ●	■ ●	■	■	■					
16	■ x ●	■ x ●	■ x ●	■ x ●	■ x ●	■ ●	■ ●	■ ●	■ ●	■ ●	■ ●	■ ●	■	■
20	■ x ●	■ x ●	■ x ●	■ x ●	■ x ●	■ ●	■ ●	■ ●	■ ●	■ ●	■ ●	■ ●	■ ●	■ ●
25	■ x ●	■ x ●	■ x ●	■ x ●	■ x ●	■ ●	■ ●	■ ●	■ ●	■ ●	■ ●	■ ●	■ ●	■ ●
32	■ x ●	■ x ●	■ x ●	■ x ●	■ x ●	■ ●	■ ●	■ ●	■ ●	■ ●	■ ●	■ ●	■ ●	■ ●
40	■ x ●	■ x ●	■ x ●	■ x ●	■ x ●	■ ●	■ ●	■ ●	■ ●	■ ●	■ ●	■ ●	■ ●	■ ●
50	■ x ●	■ x ●	■ x ●	■ x ●	■ x ●	■ ●	■ ●	■ ●	■ ●	■ ●	■ ●	■ ●	■ ●	■ ●
63	■ x ●	■ x ●	■ x ●	■ x ●	■ x ●	■ ●	■ ●	■ ●	■ ●	■ ●	■ ●	■ ●	■ ●	■ ●
80	■ x ●	■ x ●	■ x ●	■ x ●	■ x ●	■ ●	■ ●	■ ●	■ ●	■ ●	■ ●	■ ●	■ ●	■ ●
100	■ x ●	■ x ●	■ x ●	■ x ●	■ x ●	■ ●	■ ●	■ ●	■ ●	■ ●	■ ●	■ ●	■ ●	■ ●

**CODIFICATION DES VERINS SERIES QP ET QPR**

<b>QP</b>	<b>2</b>	<b>A</b>	<b>050</b>	<b>A</b>	<b>050</b>	
<b>QP</b>	SERIE : QP = standard QPR = standard anti-rotation					
<b>2</b>	FONCTIONNEMENT : 1 = simple effet( ressort ant. ) seulement QP 2 = double effet 3 = double, tige traversante		SYMBOLES PNEUMATIQUES CS09 CD07 CD14			
<b>A</b>	MATERIAUX : A = tige inox roulée, corps aluminium					
<b>050</b>	ALESAGE : 012 = 12 mm 016 = 16 mm 020 = 20 mm 025 = 25 mm 032 = 32 mm 040 = 40 mm 050 = 50 mm 063 = 63 mm 080 = 80 mm 100 = 100 mm					
<b>A</b>	ACCESSOIRES : A = standard					
<b>050</b>	COURSE : ( voir tableau )					
= standard V = joint de tige FKM W = tous joints FKM ( sauf ∅ 12 )						

VÉRINS COURSE BREVE SÉRIE QP ET QPR

**SYMBOLES PNEUMATIQUES**

Les symboles pneumatiques indiqués dans la CODIFICATION sont représentés ci-dessous.



## VERINS COURSE BREVE SERIES QP

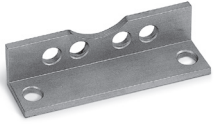

Jeu de pieds Mod. B

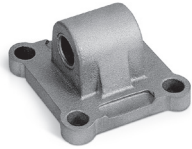

Charnière mâle Mod. L

VÉRINS COURSE BREVE SÉRIE QP ET QPR



Les accessoires sont livrés non montés sur les vérins

MOMENT DE TORSION EN FONCTION DE LA COURSE C

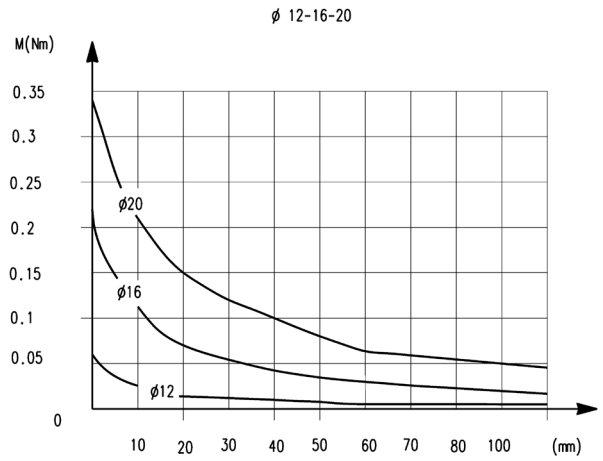
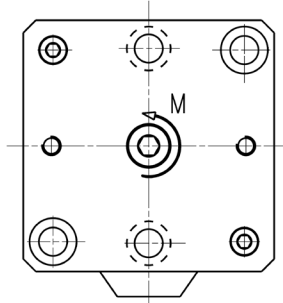

VÉRINS COURSE BRÈVE SÉRIE QP ET QPR

MOMENT DE TORSION EN FONCTION DE LA COURSE C

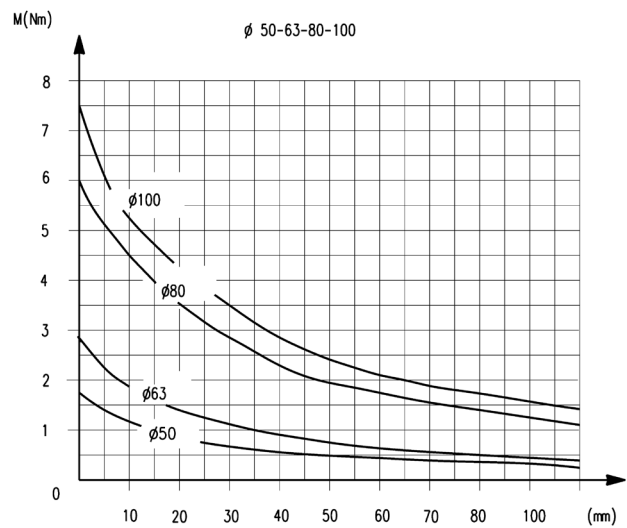
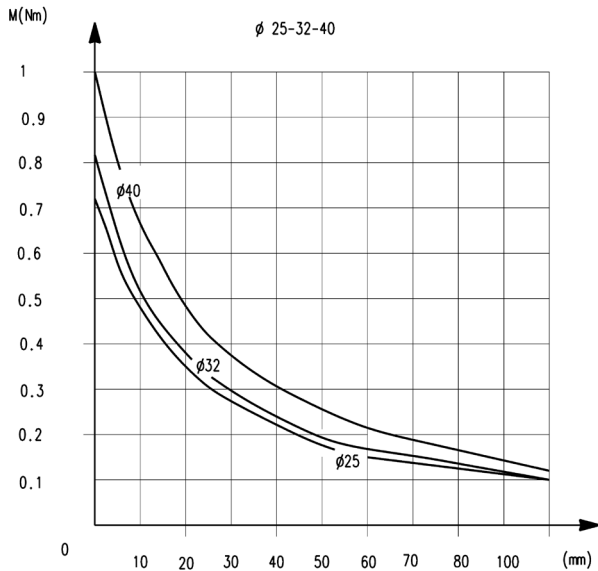

EFFORT TRANSVERSAL EN FONCTION DE LA PROJECTION "X"

VÉRINS COURSE BRÈVE SÉRIE QP ET QPR

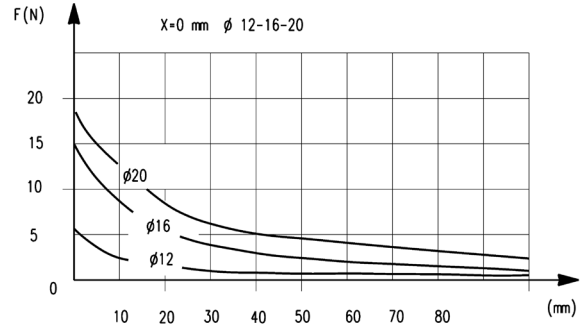
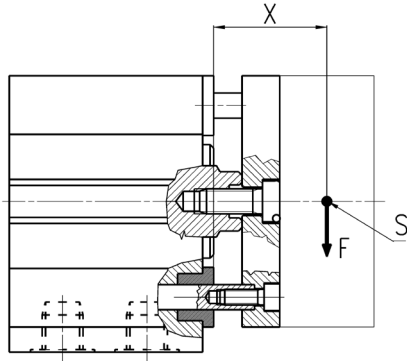

EFFORT TRANSVERSAL EN FONCTION DE LA PROJECTION "X"

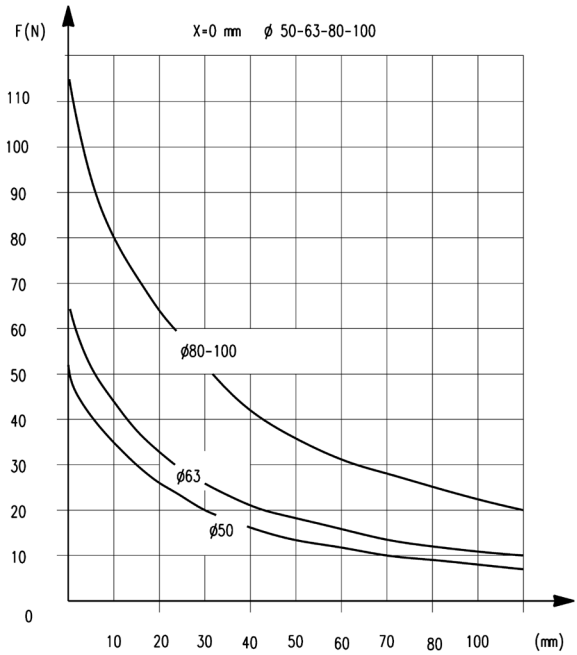
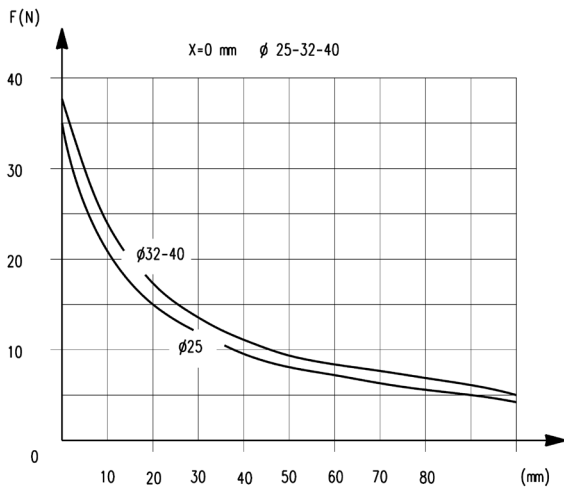

F = effort transversal

Vérins course brève Série QP



Note : La butée mécanique de fin de course du vérin doit être placée à l'extérieur.  
Pour les vérins simple effet Ø12, 16, 20 et 25, ajouter 5mm au cotes G+, G1+ et N+.

+ signifie ajouter la course

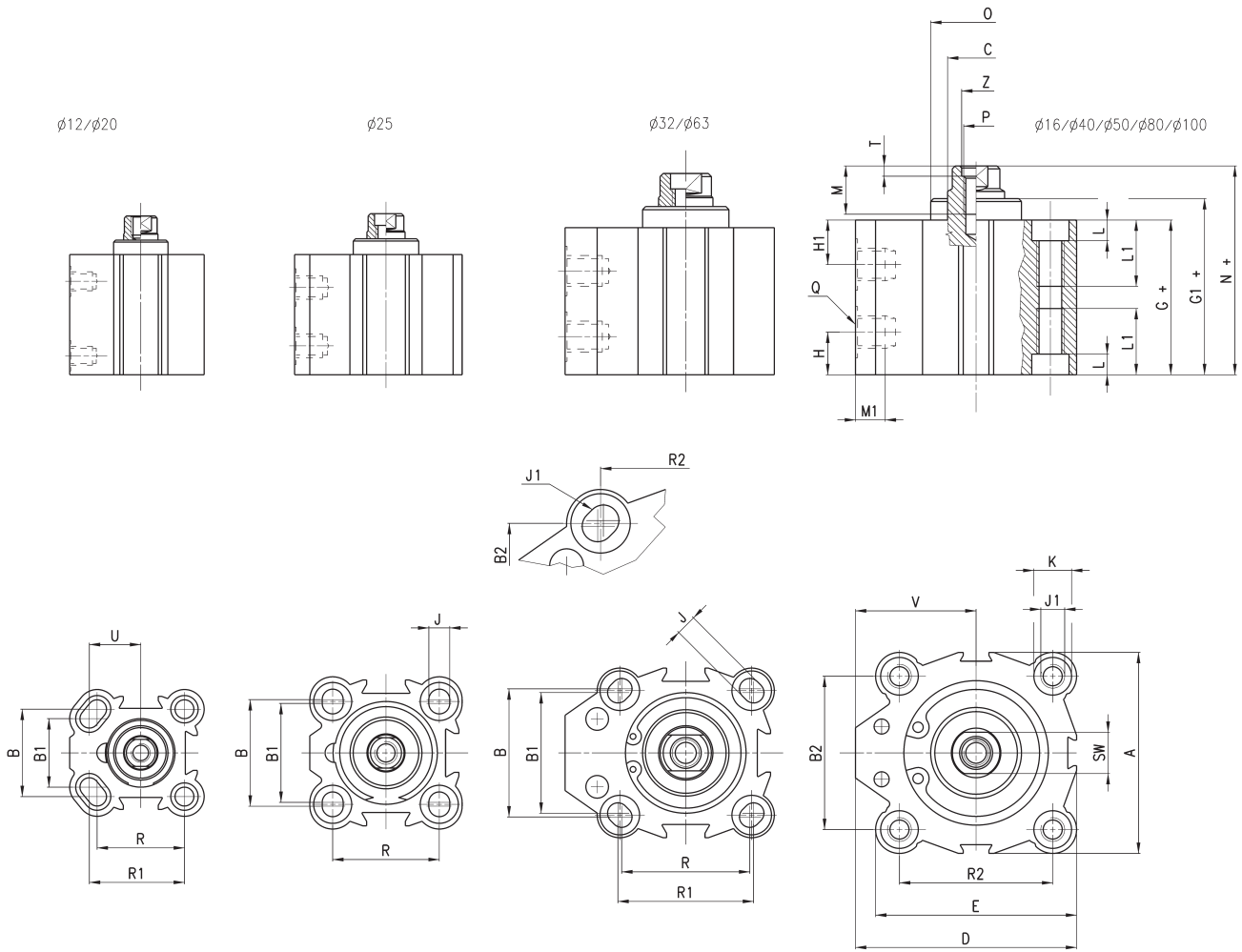

DIMENSIONS																														
Ø	A	B	B1	B2	C	D	E	G+	G1+	H1	H	J	J1	K	L	L1	M	M1	N+	O	P	Q	R	R1	R2	SW	T	U	V	Z
12	23.8	15.5	13	-	6	25	25	29.6	29.6	12.3	7.8	3.5	-	5.8	3	-	5.5	4.5	32.9	-	M3	M5	15.5	16.75	-	5	-	9	13.15	-
16	29	20	-	-	8	29	29	32	32.4	10.9	8.7	3.5	-	5.8	3	-	8	4.5	36.4	16.6	M4	M5	20	-	-	6	-	-	14.5	-
20	37	25.5	20	-	10	39.25	39.25	31.2	31.7	9.8	9.8	5.5	-	9	6	-	8	4.5	36	19.5	M6	M5	25.5	27.75	-	8	-	15	20.75	-
25	40	28	26	-	10	40	40	32.1	33.5	8	6.9	5.5	-	10	5.5	-	8	4.5	37.5	22	M6	M5	28	-	-	8	-	-	20	-
32	45	34	32	33	12	55.5	47	39.5	40	9.5	9.5	5.5	M8	10.5	6	21	10	7.5	44	23.5	M6	G1/8	34	36	35	10	2.5	-	32	7
40	52	-	-	40	16	57	52	42.4	43.4	10.7	10.7	5.5	M8	9	6	21	13.5	7.5	47.9	29.6	M8	G1/8	-	-	40	13	3.5	-	31	8.5
50	64	-	-	50	16	72	64	42.2	44	11.2	11.2	6.5	M8	10.5	6	21	13.5	9	48.4	37.5	M8	G1/4	-	-	50	13	3.5	-	40	8.5
63	80	62	60	61	20	88	80	49.5	50.1	13	13	8.5	M12	15	8.5	31.5	13.5	9	54	50	M8	G1/4	60	62	61	17	4	-	48	8.5
80	98	-	-	77	25	104	98	57.5	58.1	16.2	16.2	10.5	M12	17	10.5	31.5	15	10.5	63.5	62	M16	G3/8	-	-	77	22	4	-	55	16.5
100	117	-	-	94	25	123.5	117	68.5	69.1	20.3	20.3	10.5	M12	17	10.5	31.5	15	10.5	74.5	80	M16	G3/8	-	-	94	22	4	-	65	16.5

Vérins course brève Série QP

Note : La butée mécanique de fin de course du vérin doit être placée à l'extérieur.



+ signifie ajouter la course  
++ signifie ajouter 2 fois la course

VÉRINS COURSE BRÈVE SÉRIE QP ET QPR

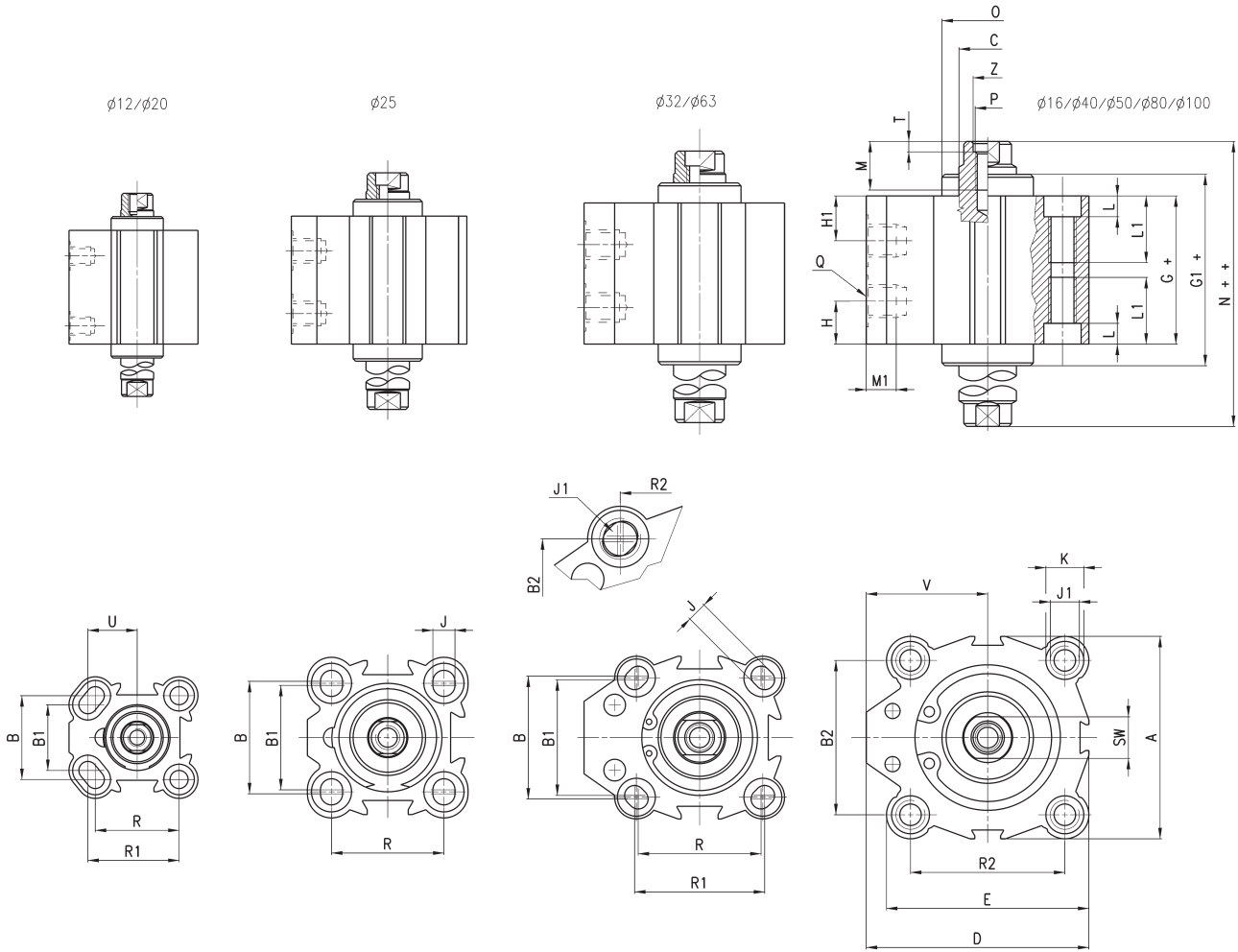

DIMENSIONS																														
$\emptyset$	A	B	B1	B2	$\emptyset C^{h8}$	D	E	G+	G1+	H1	H	J	J1	K	L	L1	M	M1	N++	$\emptyset O$	P	Q	R	R1	R2	SW	T	U	V	Z
12	23.8	15.5	13	-	6	25	25	34.5	34.5	12.3	12.3	3.5	-	5.8	3	-	5.5	4.5	41	-	M3	M5	15.5	16.75	-	5	-	9	13.15	-
16	29	20	-	-	8	29	29	38	38.8	10.9	10.9	3.5	-	5.8	3	-	8	4.5	46.4	16.6	M4	M5	20	-	-	6	-	-	14.5	-
20	37	25.5	20	-	10	39.25	39.25	38.1	39.1	9.8	9.8	5.5	-	9	6	-	8	4.5	47.7	19.5	M6	M5	25.5	27.75	-	8	-	15	20.75	-
25	40	28	26	-	10	40	40	36.3	39.1	8	8	5.5	-	10	5.5	-	8	4.5	47.1	22	M6	M5	28	-	-	8	-	-	20	-
32	45	34	32	33	12	55.5	47	39.5	40.5	9.5	9.5	5.5	M8	10.5	6	21	10	7.5	48.5	23.5	M6	G1/8	34	36	35	10	2.5	-	32	7
40	52	-	-	40	16	57	52	42.4	44.4	10.7	10.7	5.5	M8	9	6	21	13.5	7.5	53.4	29.6	M8	G1/8	-	-	40	13	3.5	-	31	8.5
50	64	-	-	50	16	72	64	42.2	45.8	11.2	11.2	6.5	M8	10.5	6	21	13.5	9	54.8	37.5	M8	G1/4	-	-	50	13	3.5	-	40	8.5
63	80	62	60	61	20	88	80	49.5	50.7	13	13	8.5	M12	15	8.5	31.5	13.5	9	58.5	50	M8	G1/4	60	62	61	17	4	-	48	8.5
80	98	-	-	77	25	104	98	57.5	58.7	16.2	16.2	10.5	M12	17	10.5	31.5	15	10.5	69.5	62	M16	G3/8	-	-	77	22	4	-	55	16.5
100	117	-	-	94	25	123.5	117	68.5	69.7	20.3	20.3	10.5	M12	17	10.5	31.5	15	10.5	80.5	80	M16	G3/8	-	-	94	22	4	-	65	16.5

Vérins course brève Série QPR

Note : La butée mécanique de fin de course du vérin doit être placée à l'extérieur.



+ signifie ajouter la course

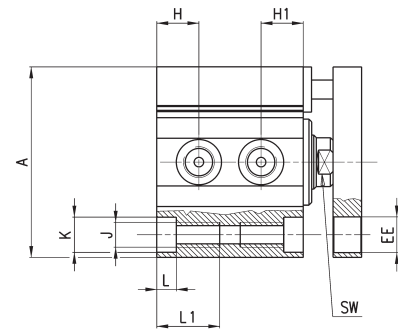
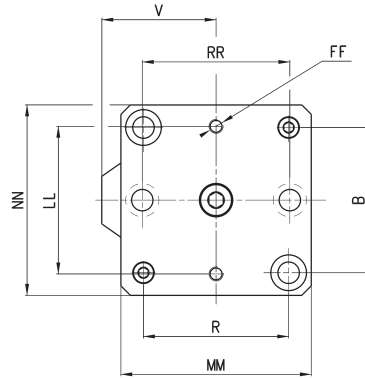
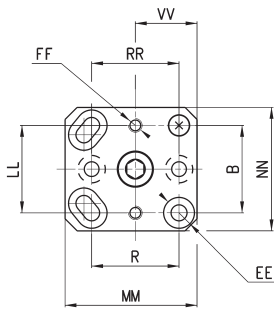
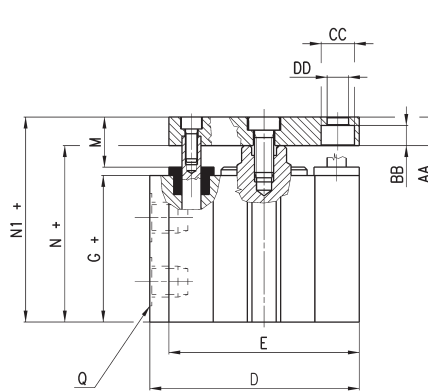
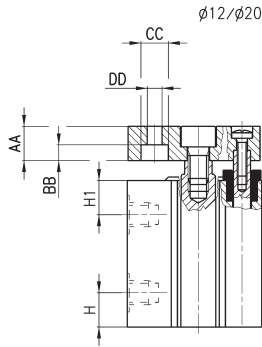

DIMENSIONS																												
Ø	A	B	D	E	G+	H1	H	J	K	L	L1	N+	N1+	Q	R	SW	V	AA	BB	CC	DD	EE	FF	LL	MM	NN	RR	VV
12	23.8	15.5	25	25	29.6	12.3	7.8	3.5	5.8	3	-	32.9	37.9	M5	15.5	5	13.15	5	3.5	6.2	3.2	5.8	M3	15.5	25	24	15.5	12
16	29	20	29	29	32	10.9	8.7	3.5	5.8	3	-	36.4	41.4	M5	20	6	14.5	5	3.5	6.2	3.2	6.5	M3	20	28	28	20	-
20	37	25.5	39.25	39.25	31.2	9.8	9.8	5.5	9	6	-	36	46	M5	25.5	8	20.75	10	4.6	8	4.2	9	M4	25.5	38.5	36	25.5	18
25	40	28	40	40	32.1	8	6.9	5.5	10	5.5	-	37.5	47.5	M5	28	8	20	10	4.6	8	4.2	10	M4	27	40	40	28	-
32	45	33	55.5	47	39.5	9.5	9.5	M8	10.5	6	21	44	54	G1/8	35	10	32	10	6	9	5.5	9	M5	32	47	45	36	-
40	52	40	57	52	42.4	10.7	10.7	M8	9	6	21	47.9	57.9	G1/8	40	13	31	10	6	9	5.5	9	M5	40	52	50	40	-
50	64	50	72	64	42.2	11.2	11.2	M8	10.5	6	21	48.4	60.4	G1/4	50	13	40	12	6.8	10.5	6.5	10	M6	50	65	65	50	-
63	80	61	88	80	49.5	13	13	M12	15	8.5	31.5	54	66	G1/4	61	17	48	12	8.5	14	9	15	M6	62	80	80	62	-
80	98	77	104	98	57.5	16.2	16.2	M12	17	10.5	31.5	63.5	78.5	G3/8	77	22	55	15	10	16.5	11	17	M8	77	100	100	77	-
100	117	94	123.5	117	68.5	20.3	20.3	M12	17	10.5	31.5	74.5	89.5	G3/8	94	22	65	15	10	16.5	11	17	M8	94	115	115	94	-

VÉRINS COURSE BRÈVE SÉRIE QP ET QPR



Vérins course brève Série QPR

Note : La butée mécanique de fin de course du vérin doit être placée à l'extérieur.



+ signifie ajouter la course  
++ signifie ajouter 2 fois la course

VÉRINS COURSE BRÈVE SÉRIE QP ET QPR

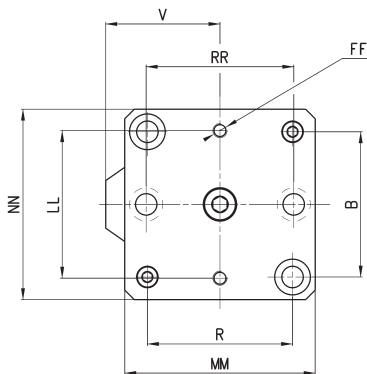
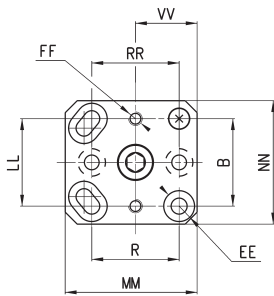
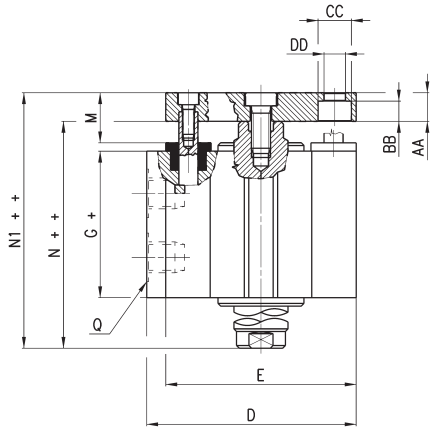
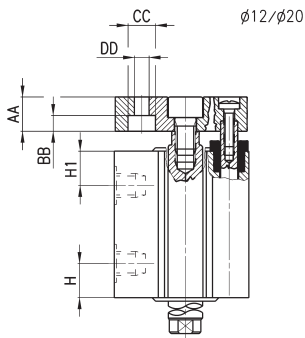

∅16/∅25/∅32/∅40/∅50/∅63/∅80/∅100

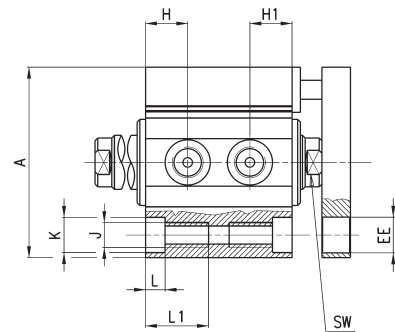

DIMENSIONS																												
∅	A	B	D	E	G+	H1	H	J	K	L	L1	N++	N1++	Q	R	SW	V	AA	BB	CC	DD	EE	FF	LL	MM	NN	RR	VV
12	23.8	15.5	25	25	37.3	12.3	12.3	3.5	5.8	3	-	41	46	M5	15.5	5	13.15	5	3.5	6.2	3.2	5.8	M3	15.5	25	24	15.5	12
16	29	20	29	29	38	10.9	10.9	3.5	5.8	3	-	47	52	M5	20	6	14.5	5	3.5	6.2	3.2	6.5	M3	20	28	28	20	-
20	37	25.5	39.25	39.25	38.1	9.8	9.8	5.5	9	6	-	47.7	57.7	M5	25.5	8	20.75	10	4.6	8	4.2	9	M4	25.5	38.5	36	25.5	18
25	40	28	40	40	36.3	8	8	5.5	10	5.5	-	47.1	57.1	M5	28	8	20	10	4.6	8	4.2	10	M4	27	40	40	28	-
32	45	33	55.5	47	39.5	9.5	9.5	M8	10.5	6	21	48.5	58.5	G1\8	35	10	32	10	6	9	5.5	9	M5	32	47	45	36	-
40	52	40	57	52	42.4	10.7	10.7	M8	9	6	21	53.4	63.4	G1\8	40	13	31	10	6	9	5.5	9	M5	40	52	50	40	-
50	64	50	72	64	42.2	11.2	11.2	M8	10.5	6	21	54.8	66.8	G1\4	50	13	40	12	6.8	10.5	6.5	10	M6	50	65	65	50	-
63	80	61	88	80	49.5	13	13	M12	15	8.5	31.5	58.5	70.5	G1\4	61	17	48	12	8.5	14	9	15	M6	62	80	80	62	-
80	98	77	104	98	57.5	16.2	16.2	M12	17	10.5	31.5	69.5	84.5	G3\8	77	22	55	15	10	16.5	11	17	M8	77	100	100	77	-
100	117	94	123.5	117	68.5	20.3	20.3	M12	17	10.5	31.5	80.5	95.5	G3\8	94	22	65	15	10	16.5	11	17	M8	94	115	115	94	-

**Charnière mâle Mod. L**

Matériau : aluminium

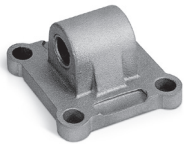

Complet avec:  
1x charnière mâle  
4x vis

+ signifie ajouter la course

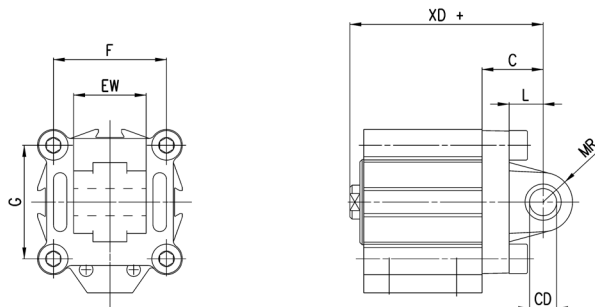

DIMENSIONS									
Mod.	∅	CD <sup>H9</sup>	MR	L	C	XD+	F	G	EW
L-QP-32	32	10	9	12	22	66	33	35	26
L-QP-40	40	12	13	15	25	73	40	40	28
L-QP-50	50	12	13	15	27	75,5	50	50	32
L-QP-63	63	16	15	20	32	86	61	61	40
L-QP-80	80	16	15	24	36	99,5	77	77	50
L-QP-100	100	20	18	29	41	115,5	94	94	60

**Jeu de pieds Mod. B**

Matériau : acier zingué



Complet avec:  
2x pieds  
4x vis

+ signifie ajouter la course

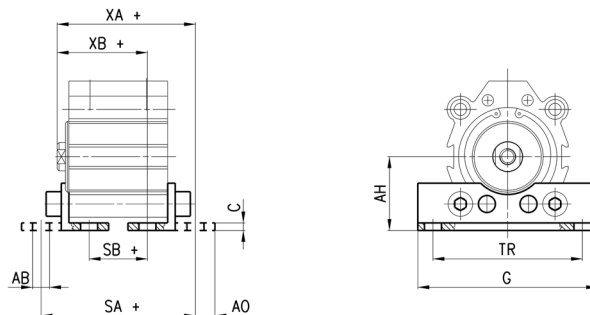

DIMENSIONS											
Mod.	∅	C	SA+	XA+	SB+	XB+	TR	G	AB	AH	AO
B-QP-32	32	3	61.9	55.2	23.1	35.8	57	71	6.6	30	8.8
B-QP-40	40	3	64.8	59.1	26	39.7	64	78	6.6	33	8.8
B-QP-50	50	4	71.6	63.1	20.8	37.7	79	95	9	39	10.3
B-QP-63	63	4	81.9	70.2	25.1	41.8	95	113	11	46	13.8
B-QP-80	80	6	96.5	83	30.5	49	118	140	13	59	10.5
B-QP-100	100	6	114.5	97.5	22.5	51.5	137	162	13	71	17