

VSAG

Ventouses 1.5 soufflets Ø 10 à 150 mm



Les ventouses 1.5 soufflets série VSAG sont recommandées pour la préhension de pièces sensibles grâce à l'effet amortissant des soufflets, ou pour la préhension d'objet légèrement concaves ou convexes. Elles permettent aussi de compenser des variations de hauteurs de prises de pièces.

Domaines d'activité

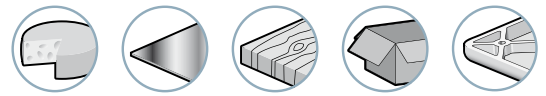





Cas d'emploi



Matières

NBR Nitrile
SI Silicone translucide
STN Siton®

Caractéristiques ventouses

	Ø (mm)	 (cm ³)	 (N) ⁽¹⁾	 (N) ⁽¹⁾	 R _{min} (mm)	NBR	SI	STN
VSAG 10	10.7	0.2	1.8	0.9	4	VSAG10NBR	VSAG10SI	VSAG10STN
VSAG 15	15	0.7	2.5	1.3	6	VSAG15NBR	VSAG15SI	VSAG15STN
VSAG 20B	20	1	4.8	2.4	8	VSAG20BNBR	VSAG20BSI	VSAG20BSTN
VSAG 30	30	4	15.2	7.6	15	VSAG30NBR	VSAG30SI	-
VSAG 40	40	9	23.1	11.6	30	VSAG40NBR	VSAG40SI	-
VSAG 50	50	26	38.3	18.8	40	VSAG50NBR	VSAG50SI	-
VSAG 75	75	76	90.3	44.8	70	VSAG75NBR	VSAG75SI	VSAG75STN
VSAG 110	110	280	191.4	93.9	100	VSAG110NBR	VSAG110SI	VSAG110STN
VSAG 150	150	640	377.7	187.8	130	VSAG150NBR	VSAG150SI	-

(1) Force pratique de la ventouse avec un vide de 65% et un coefficient de sécurité de 2 inclus pour manipulation horizontale et coefficient de 4 inclus pour manipulation verticale.

Choix des inserts

 (Ø)	M5-F	M5-M	M6-M	M10-M	M10x125F	G1/8"-M	G1/8"-F	G1/4"-M	G1/4"-F	G1/2"-F
10...15	■	■	-	-	-	■	■	-	-	-
20...50	-	-	■	□	-	■	■	■	■	-
75	-	-	-	-	■	-	-	■	■	-
110...150	-	-	-	-	-	-	-	-	-	■

■ Combinaisons «ventouse + insert» disponibles
 Voir références page 2/34



□ Solutions de montage additionnelles
 Voir page 2/36

Fixation : M = mâle F = femelle

Types de montage

Les ventouses COVAL disposent d'une grande modularité de montage :

C   **Version C**
 insert canule

V   **Version V**
 insert démontable
 (vis creuse et adaptateur)



Préciser référence ex. : VSAG10NBRIM18C
Se reporter à la page 2/34

Accessoires

Afin d'optimiser l'utilisation de vos ventouses, Coval propose toute une gamme d'accessoires (inserts buses, systèmes ressort, rallonges, nourrices, etc.), voir chapitres 4 et 12.

VSAG

Ventouses 1.5 soufflets Ø 10 à 150 mm

Références « ventouse + insert »



2

C

FILETAGE	M5-M	M5-F	G1/8"-M	G1/8"-F
Ø 10 - 15 mm				
VSAG10NBR	VSAG10NBRIMM5C	VSAG10NBRIFM5C	VSAG10NBRIM18C	VSAG10NBRIF18C
VSAG10SI	VSAG10SIIMM5C	VSAG10SIIFM5C	VSAG10SIIM18C	VSAG10SIIF18C
VSAG10STN	VSAG10STNIMM5C	VSAG10STNIFM5C	VSAG10STNIM18C	VSAG10STNIF18C
VSAG15NBR	VSAG15NBRIMM5C	VSAG15NBRIFM5C	VSAG15NBRIM18C	VSAG15NBRIF18C
VSAG15SI	VSAG15SIIMM5C	VSAG15SIIFM5C	VSAG15SIIM18C	VSAG15SIIF18C
VSAG15STN	VSAG15STNIMM5C	VSAG15STNIFM5C	VSAG15STNIM18C	VSAG15STNIF18C

C **V**

FILETAGE	G1/8"-M	G1/8"-F	M6-M	G1/8"-M	G1/8"-F	G1/4"-M	G1/4"-F
Ø 20 - 50 mm							
VSAG20BNBR	VSAG20BNBRIM18C	VSAG20BNBRIF18C	VSAG20BNBRIMM6V	VSAG20BNBRIM18V	VSAG20BNBRIF18V	VSAG20BNBRIM14V	VSAG20BNBRIF14V
VSAG20BSI	VSAG20BSIIM18C	VSAG20BSIIF18C	VSAG20BSIIMM6V	VSAG20BSIIM18V	VSAG20BSIIF18V	VSAG20BSIIM14V	VSAG20BSIIF14V
VSAG20BSTN	VSAG20BSTNIM18C	VSAG20BSTNIF18C	VSAG20BSTNIMM6V	VSAG20BSTNIM18V	VSAG20BSTNIF18V	VSAG20BSTNIM14V	VSAG20BSTNIF14V
VSAG30NBR	VSAG30NBRIM18C	VSAG30NBRIF18C	VSAG30NBRIMM6V	VSAG30NBRIM18V	VSAG30NBRIF18V	VSAG30NBRIM14V	VSAG30NBRIF14V
VSAG30SI	VSAG30SIIM18C	VSAG30SIIF18C	VSAG30SIIMM6V	VSAG30SIIM18V	VSAG30SIIF18V	VSAG30SIIM14V	VSAG30SIIF14V
VSAG40NBR	VSAG40NBRIM18C	VSAG40NBRIF18C	VSAG40NBRIMM6V	VSAG40NBRIM18V	VSAG40NBRIF18V	VSAG40NBRIM14V	VSAG40NBRIF14V
VSAG40SI	VSAG40SIIM18C	VSAG40SIIF18C	VSAG40SIIMM6V	VSAG40SIIM18V	VSAG40SIIF18V	VSAG40SIIM14V	VSAG40SIIF14V
VSAG50NBR	VSAG50NBRIM18C	VSAG50NBRIF18C	VSAG50NBRIMM6V	VSAG50NBRIM18V	VSAG50NBRIF18V	VSAG50NBRIM14V	VSAG50NBRIF14V
VSAG50SI	VSAG50SIIM18C	VSAG50SIIF18C	VSAG50SIIMM6V	VSAG50SIIM18V	VSAG50SIIF18V	VSAG50SIIM14V	VSAG50SIIF14V

V

FILETAGE	M10x125 F	G1/4"-M	G1/4"-F
Ø 75 mm			
VSAG75NBR	VSAG75NBR	VSAG75NBRIM14V	VSAG75NBRIF14V
VSAG75SI	VSAG75SI	VSAG75SIIM14V	VSAG75SIIF14V
VSAG75STN	VSAG75STN	VSAG75STNIM14V	VSAG75STNIF14V

V

FILETAGE	G1/2"-F *	G1/2"-F **
Ø 110 - 150 mm		
VSAG110NBR	VSAG110NBRIFS12V	VSAG110NBRIF12V
VSAG110SI	VSAG110SIIFS12V	VSAG110SIIF12V
VSAG110STN	VSAG110STNIFS12V	VSAG110STNIF12V
VSAG150NBR	VSAG150NBRIFS12V	VSAG150NBRIF12V
VSAG150SI	VSAG150SIIFS12V	VSAG150SIIF12V

* Montage avec insert IFS12120

** Montage avec insert IF12120

Des solutions de montage additionnelles sont disponibles (voir page 2/36)
Les combinaisons « ventouse+insert » sont livrées non assemblées.

VSAG

Ventouses 1.5 soufflets Ø 10 à 150 mm

Encombrements « ventouse + insert »



2 VSAG

VSAG 10 - 15

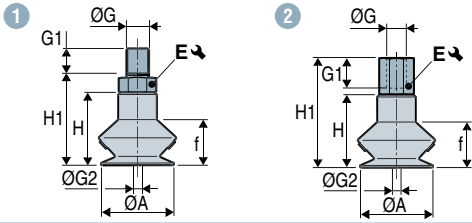

VSAG 20B - 50

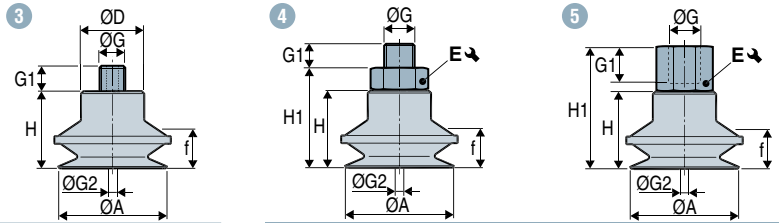

VSAG 75

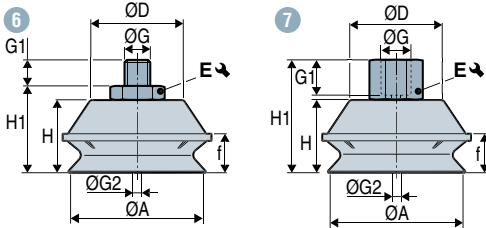

VSAG 110 - 150



	Schéma	ØA	ØD	f ⁽¹⁾	H	H1	ØG	G1	ØG2 ⁽²⁾	E ↘	⊖ (g)	
Ø 10 - 15 mm	VSAG10---IMM5C	1	10.7	-	5	13.3	16.8	M5-M	4.5	2.2	7	1.3
	VSAG10---IFM5C	2	10.7	-	5	13.3	22.3	M5-F	6	2.2	14	1.8
	VSAG10---IM18C	1	10.7	-	5	13.3	18.3	G1/8"-M	8	2.2	14	4.5
	VSAG10---IF18C	2	10.7	-	5	13.3	28.3	G1/8"-F	9	2.2	14	5.7
	VSAG15---IMM5C	1	15	-	10	16	19.5	M5-M	4.5	2.2	7	1.6
	VSAG15---IFM5C	2	15	-	10	16	25	M5-F	6	2.2	14	2.1
	VSAG15---IM18C	1	15	-	10	16	21	G1/8"-M	8	2.2	14	4.8
VSAG15---IF18C	2	15	-	10	16	31	G1/8"-F	9	2.2	14	6	
Ø 20B - 40 mm	VSAG20B---IM18C	4	20	-	12	22	27	G1/8"-M	8	4	14	7.1
	VSAG20B---IF18C	5	20	-	12	22	37	G1/8"-F	9	4	14	8.5
	VSAG20B---IMM6V	3	20	15	12	22	-	M6-M	6	3.5	-	5.7
	VSAG20B---IM18V	4	20	-	12	22	26.5	G1/8"-M	6	3.5	13	12.3
	VSAG20B---IF18V	5	20	-	12	22	35	G1/8"-F	7.5	3.5	13	15.6
	VSAG20B---IM14V	4	20	-	12	22	27	G1/4"-M	8	3.5	17	21.6
	VSAG20B---IF14V	5	20	-	12	22	38	G1/4"-F	11	3.5	17	26.2
	VSAG30---IM18C	4	30	-	17	30.5	35.5	G1/8"-M	8	4	14	13.2
	VSAG30---IF18C	5	30	-	17	30.5	45.5	G1/8"-F	9	4	14	14.6
	VSAG30---IMM6V	3	30	20	17	30.5	-	M6-M	6	3.5	-	11.8
	VSAG30---IM18V	4	30	-	17	30.5	35	G1/8"-M	6	3.5	13	18.4
	VSAG30---IF18V	5	30	-	17	30.5	43.5	G1/8"-F	7.5	3.5	13	21.7
	VSAG30---IM14V	4	30	-	17	30.5	35.5	G1/4"-M	8	3.5	17	27.7
	VSAG30---IF14V	5	30	-	17	30.5	46.5	G1/4"-F	11	3.5	17	32.3
	VSAG40---IM18C	4	40	-	15.5	30.5	35.5	G1/8"-M	8	4	14	18.8
	VSAG40---IF18C	5	40	-	15.5	30.5	45.5	G1/8"-F	9	4	14	20.2
VSAG40---IMM6V	3	40	25	15.5	30.5	-	M6-M	6	3.5	-	17.4	
VSAG40---IM18V	4	40	-	15.5	30.5	35	G1/8"-M	6	3.5	13	24	
VSAG40---IF18V	5	40	-	15.5	30.5	43.5	G1/8"-F	7.5	3.5	13	27.3	
VSAG40---IM14V	4	40	-	15.5	30.5	35.5	G1/4"-M	8	3.5	17	33.3	
VSAG40---IF14V	5	40	-	15.5	30.5	46.5	G1/4"-F	11	3.5	17	37.9	
Ø 50 mm	VSAG50---IM18C	4	50	-	20	36.5	41.5	G1/8"-M	8	4	14	27.4
	VSAG50---IF18C	5	50	-	20	36.5	51.5	G1/8"-F	9	4	14	28.8
	VSAG50---IMM6V	3	50	-	20	36.5	-	M6-M	6	3.5	-	30
	VSAG50---IM18V	4	50	-	20	36.5	41	G1/8"-M	6	3.5	13	36.6
	VSAG50---IF18V	5	50	-	20	36.5	49.5	G1/8"-F	7.5	3.5	13	40
	VSAG50---IM14V	4	50	-	20	36.5	41.5	G1/4"-M	8	3.5	17	45.9
	VSAG50---IM14F	5	50	-	20	36.5	52.5	G1/4"-F	11	3.5	17	50.4
Ø 75 - 150 mm	VSAG75---	8	75	50.5	22	43.2	-	M10x125-F	-	-	-	87.6
	VSAG75---IM14V	6	75	50.5	22	43.2	48.2	G1/4"-M	10	5	17	94.6
	VSAG75---IF14V	7	75	50.5	22	43.2	60.2	G1/4"-F	10	5	17	95.9
	VSAG110---IF12V	10	110	85	32.5	55	85	G1/2"-F	24	19	48	488.8
	VSAG110---IFS12V	9	110	85	32.5	55	68	G1/2"-F	13	-	-	407.5
	VSAG150---IF12V	10	150	120	39.5	75.5	105.5	G1/2"-F	24	19	48	911.4
VSAG150---IFS12V	9	150	120	39.5	75.5	88.5	G1/2"-F	13	-	-	830.1	

Note : toutes les cotes sont indiquées en mm (1) f = Flèche de la ventouse. (2) Ø G2 = Ø de passage intérieur de l'insert.

VSAG

Ventouses 1.5 soufflets Ø 10 à 150 mm

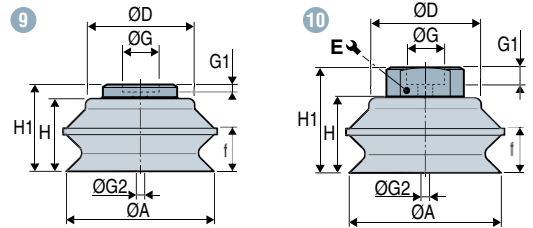
Schémas de montage



2
VSAG

VSAG 10 - 15

Inserts canules **C**

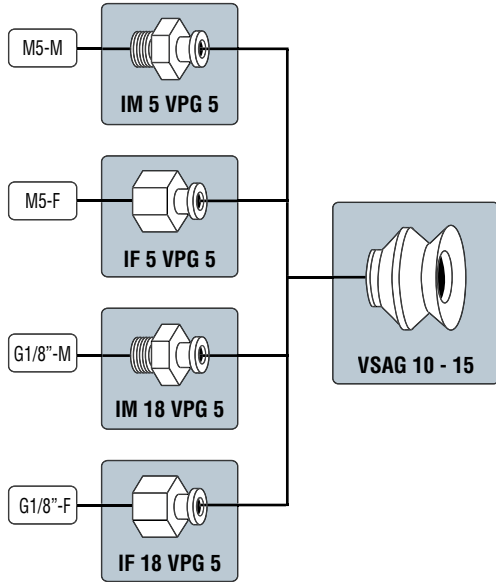

VSAG 20B - 50

Inserts canules **C**

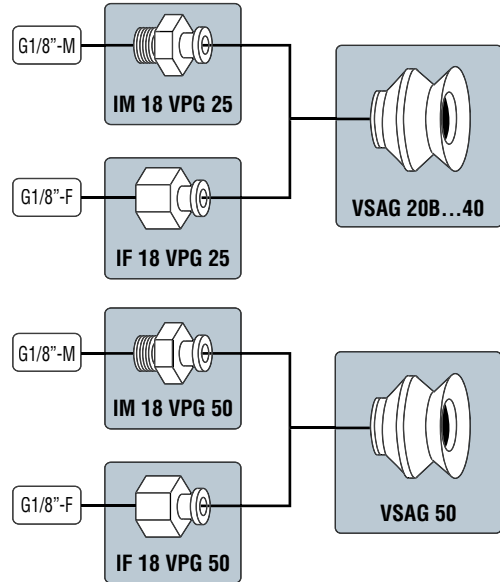

VSAG 20B - 50

Inserts démontables **V**

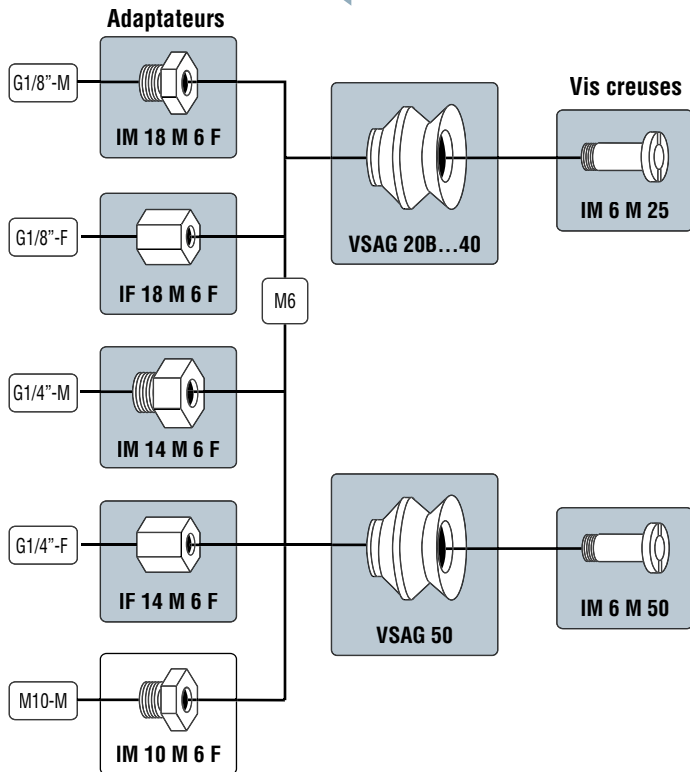

VSAG 75 - 150

Inserts démontables **V**

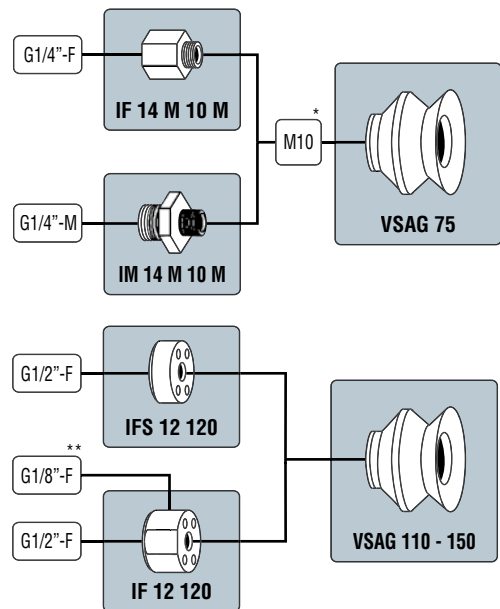

* Pas de 125

** Sortie radiale auxiliaire femelle

Combinaisons «ventouse + insert» référencées page 2/34

Solutions de montage optionnelles à commander en références séparées

Cotes d'encombrement des inserts et ventouses : voir pages 2/37 et 2/38

VSAG

Ventouses 1.5 soufflets Ø 10 à 150 mm

Encombrements ventouses



2 VSAG

VSAG 10 - 15

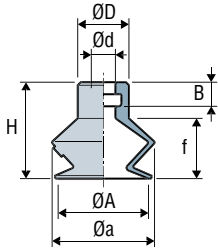

VSAG 20 - 50

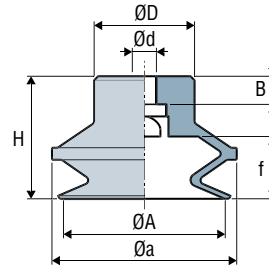

VSAG 75

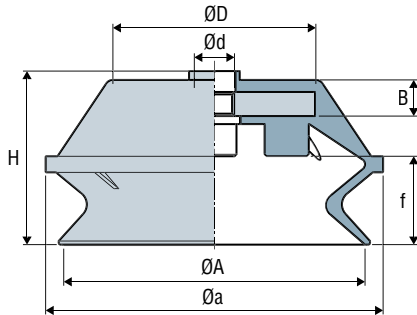

VSAG 110 - 150

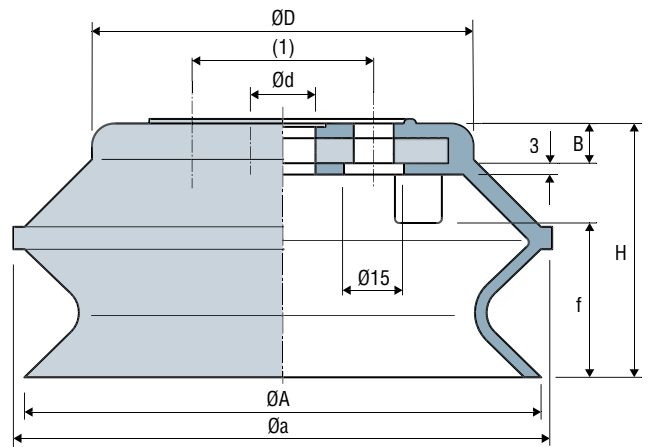

(1) 4 trous Ø 9 sur Ø 40

(Ø)	ØA	H	Øa	Ød	ØD	f ⁽¹⁾	B	(g)
VSAG 10	10.7	13.3	12.5	4	8.5	5	4	0.6
VSAG 15	15	16	17	4	8.5	10	4	0.9
VSAG 20 B	20	22	24	6	15	12	7	3
VSAG 30	30	30.5	36	6	20	17	7	9.1
VSAG 40	40	30.5	46	6	25	15.5	7	14.7
VSAG 50	50	36.5	59.5	7.8	28.5	20	7	22.5
VSAG 75	75	43.2	84	M10 x 125 - F	50.5	22	9	87.6
VSAG 110	110	55	121.5	14	85	32.5	9	264
VSAG 150	150	75.5	166	13	120	39.5	11	686.6

Les valeurs sont représentatives des caractéristiques moyennes de nos produits. (1) f = Flèche de la ventouse.
 Note : toutes les cotes sont indiquées en mm

VSAG

Ventouses 1.5 soufflets Ø 10 à 150 mm

Encombrements inserts



Inserts canules

Mâle - IM

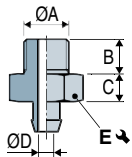

Femelle - IF

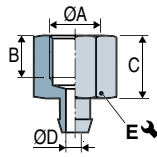

	ØA	B	C	ØD	E ↻	Matière	⚖ (g)
IM 5 VPG5	M5-M	4.5	3.5	2.2	7	Aluminium	0.7
IM 18 VPG5	G1/8"-M	8	5	2.2	14	Aluminium	3.9
IM 18 VPG25	G1/8"-M	8	5	4	14	Aluminium	4.1
IM 18 VPG50	G1/8"-M	8	5	4	14	Aluminium	4.9
IF 5 VPG5	M5-F	6	9	2.2	14	Aluminium	1.2
IF 18 VPG5	G1/8"-F	9	15	2.2	14	Aluminium	5.1
IF 18 VPG25	G1/8"-F	9	15	4	14	Aluminium	5.5
IF 18 VPG50	G1/8"-F	9	15	4	14	Aluminium	6.3

Vis creuses

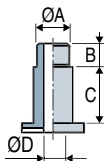

	ØA	B	C	ØD	Matière	⚖ (g)
IM 6 M25	M6-M	6	6	3.5	Laiton nickelé	2.7
IM 6 M50	M6-M	6	6	3.5	Laiton nickelé	7.5

Adaptateurs pour vis creuses

Mâle - IM

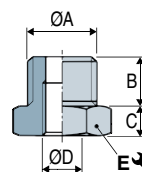

Femelle - IF

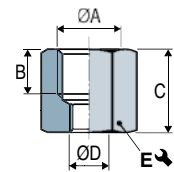

	ØA	B	C	ØD	E ↻	Matière	⚖ (g)
IM 10 M6F	M10-M	7	3.5	M6	13	Laiton Nickelé	5.9
IM 14 M6F	G1/4"-M	8	5	M6-F	17	Laiton Nickelé	15.9
IM 18 M6F	G1/8"-M	6	4.5	M6-F	13	Laiton Nickelé	6.6
IF 14 M6F	G1/4"-F	11	16	M6-F	17	Laiton Nickelé	20.5
IF 18 M6F	G1/8"-F	7.5	13	M6-F	13	Laiton Nickelé	9.9

Inserts vissés

Mâle - IM

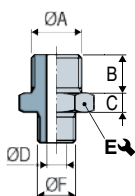

Femelle - IF

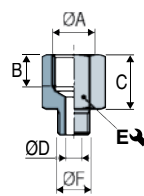

Femelle - IF 12120

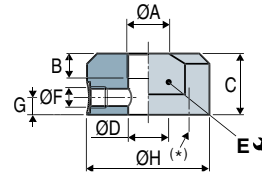

Femelle - IFS 12120

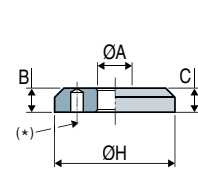

(*) 4 trous Ø M8 sur Ø 40 (vis fournies)

	ØA	B	C	ØD	E ↻	ØF	G	H	Matière	⚖ (g)
IM 14 M10M	G1/4"-M	10	5	5	17	M10x125-M	-	-	Aluminium	7
IF 14 M10M	G1/4"-F	10	17	5	17	M10x125-M	-	-	Aluminium	8.3
IF 12120	G1/2"-F	24	30	19	48	G1/8"-F	8.7	60	Aluminium	224.8
IFS 12120	G1/2"-F	13	13	-	-	-	-	65	Aluminium	143.5

Les valeurs sont représentatives des caractéristiques moyennes de nos produits.

Note : toutes les cotes sont indiquées en mm