

GEMÜ ADH, ADP, MSC, RC0

Accessories for quarter turn valves

Mounting sleeves

Mounting sleeve,
square geometry

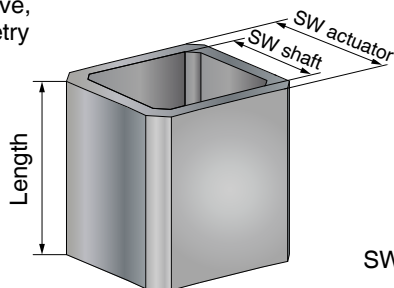

Mounting sleeve,
star-shaped geometry

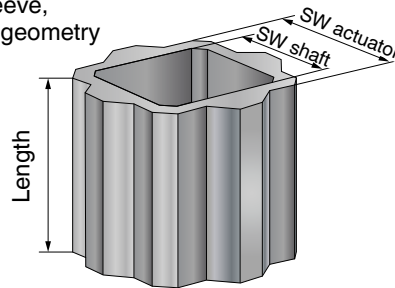

SW = wrench size

Order data

1 Type	Code
Mounting sleeve	ADH

2 Material	Code
Steel, nickel plated	N

Actuator side	
3 Flange / hub assignment	Code
Adaption actuator	A
4 Version	Code
Square	D
Star-shaped geometry*	S
5 Wrench size (SW actuator)	Code
SW 11	11
SW 14	14
SW 17	17
SW 22	22
SW 27	27
SW 36	36
SW 46	46
SW 55	55

Body side (Butterfly valve, ball valve)	
6 Flange / hub assignment	Code
Adaption body	K
7 Version	Code
Square	D
8 Wrench size (SW shaft)	Code
SW 08	08
SW 09	09
SW 11	11
SW 14	14
SW 17	17
SW 19	19
SW 22	22
SW 27	27
SW 46	46

9 Length	Code
11 mm (D11/D08, D11/D09)	11
14 mm (D14/D11, S14/D08, S14/D09, S14/D11)	14
17 mm (D17/D11, D17/D14)	17
19 mm (D11/D08)	19
22 mm (D22/D14, D22/D17, S17/D11, S17/D14)	22
25 mm (S22/D11, S22/D14, S22/D17, S22/D19)	25
27 mm (D27/D22)	27
29 mm (D27/D19)	29
36 mm (D36/D22, D11/D09)	36
39 mm (S27/D17, S27/D19, S27/D22)	39
48 mm (S36/D22, S36/D27)	48
50 mm (S46/D36)	50
65 mm (S55/D46)	65
Availability see page 3	

Order example	1	2	3	4	5	6	7	8	9
Code	ADH	N	A	S	22	K	D	19	25

*Note: Star-shaped sleeves are not suitable for actuators with a simple square

Mounting sleeves

Availability - Wrench size actuator (SWW) / body (SWN)

Actuator \ Body	SW 08	SW 09	SW 11	SW 14	SW 17	SW 19	SW 22	SW 27	SW 36	SW 46
SW 11	D	D	-	-	-	-	-	-	-	-
SW 14	S	S	D / S	-	-	-	-	-	-	-
SW 17	-	S	D / S	D / S	-	-	-	-	-	-
SW 22	-	-	S	D / S	D / S	S	-	-	-	-
SW 27	-	-	-	-	S	D / S	D / S	-	-	-
SW 36	-	-	-	-	-	-	D / S	S	-	-
SW 46	-	-	-	-	-	-	-	-	S	-
SW 55	-	-	-	-	-	-	-	-	-	S

D = Square, S = Star-shaped geometry

further mounting sleeves on request

Mounting kits

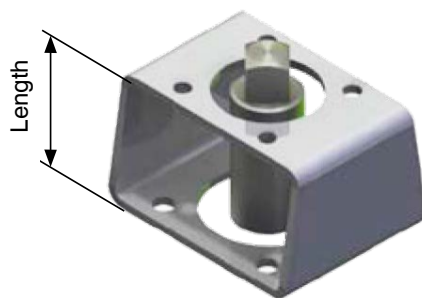

Order data

1 Type	Code
Mounting kit	MSC

2 Material	Code
Electrogalvanized	G
Stainless steel	V

Actuator side	
3 Flange / hub assignment	Code
Adaption actuator	A
4 Flange size	Code
F04	F04
F05	F05
F07	F07
F10	F10
F12	F12
F14	F14
F16	F16
G05 (for type 410, 411, 415, 417, 423, 428 and actuators 9415, 9428)	G05
5 Shaft	Code
Diagonal shaft (Square)	D
6 Wrench size	Code
SW 11	11
SW 14	14
SW 17	17
SW 22	22
SW 27	27
SW 36	36
SW 46	46

Body side (Butterfly valve, ball valve)

7 Flange / hub assignment	Code
Adaption body	K
8 Flange size	Code
F04	F04
F05	F05
F07	F07
F10	F10
F12	F12
F14	F14
F16	F16
G05 (for type 410, 411, 415, 417, 423, 428 and actuators 9415, 9428)	G05
9 Shaft	Code
Diagonal shaft	D
10 Wrench size	Code
SW 11	11
SW 14	14
SW 17	17
SW 22	22
SW 27	27
SW 36	36
SW 46	46

11 Length	Code
50 mm (F04/F04, F07/F05*)	50
60 mm (F05/F05, F05/F07, F05/F04, F07/F05, F07/F07, F07/F04,)	60
80 mm (F07/F10, F10/F07, F10/F10, F12/F10, F14/F10, F14/F10*)	80
90 mm (F14/F12)	90
100 mm (F16/F14*)	80
120 mm (F14/F16, F16/F12, F16/F14)	120

* Stainless steel, Standard = electrogalvanized

Order example	1	2	3	4	5	6	7	8	9	10	11
Code	MSC	G	A	F16	D	46	K	F14	D	36	120

Mounting plate

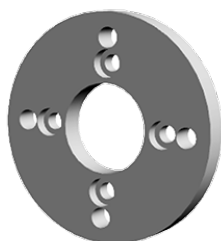

ADPA

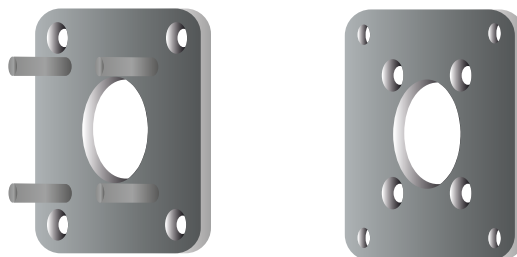

ADPG / ADPV

Order data

1 Type	Code
Adapter plate	ADP

2 Material	Code
Aluminium	A
Electrogalvanized	G
Stainless steel	V

Actuator side

3 Flange / hub assignment	Code
Adaption actuator	A

4 Flange size	Code
F04	F04
F05	F05
F07	F07
F10	F10

Body side (Butterfly valve, ball valve)

5 Flange / hub assignment	Code
Adaption body	K

6 Flange size	Code
F04	F04
F05	F05
F07	F07

7 Length	Code
4 mm (F05/F07-M8)	4
5 mm (F10/F05-M6)	5
6 mm (F10/F07-M8)	6
10 mm (F04/F07-M5, F05/F07-M6, F07/F04-M5, F07/F05-M6, F07/F05-M8, F10/F07-M10)	10
15 mm (F04/F07-M5)	15

Order example	1	2	3	4	5	6	7	8
Code	ADP	A	A	F07	K	F12	18	-

Distanzstück

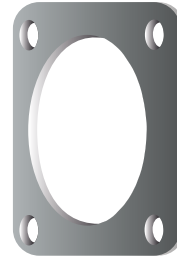

Order data

1 Type	Code
Spacer	DIS

2 Material	Code
Aluminium	A
Stainless steel	V

Actuator side	
3 Flange / hub assignment	Code
Adaption actuator	A
4 Flange size	Code
F05	F05
F07	F07
F10	F10

Body side	
5 Flange / hub assignment	Code
Adaption body	K
6 Flange size	Code
F05	F05
F07	F07
F10	F10

7 Length	Code
3 mm (F05/F05, F07/F07, F10/F10)	3
10 mm (F07/F07, F10/F10)	10

Order example	1	2	3	4	5	6	7
Code	DIS	V	A	F07	K	F07	3
				Must be identical			

Shaft extension

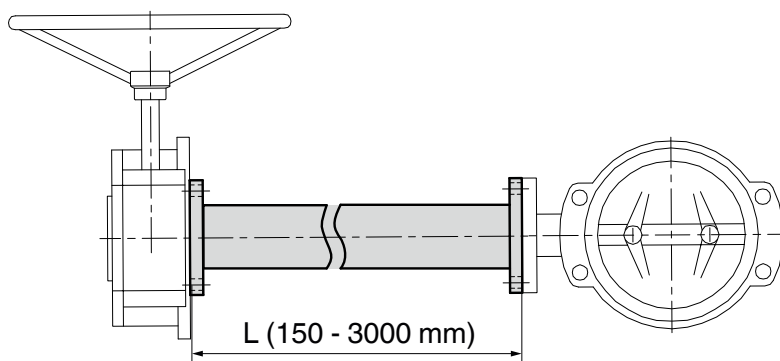

Order data - Shaft extension - Round with keys

1 Type	Code
Shaft extension	RC0

2 Material	Code
Steel S235JR, 1.0037 RAL 9005 coated	S

Actuator side	
3 Flange / hub assignment	Code
Adaption actuator	A
4 Flange size	Code
F25	F25
F30	F30
F35	F35
5 Design	Code
Round with 2 keys	W
6 Diameter	Code
48 (for F25)	48
50 (for F25)	50
60 (for F25)	60
72 (for F25)	72
80 (for F25, F30)	80
98 (for F25, F30)	98
100 (for F25, F30)	100
120 (for F30)	120
160 (for F35)	160

Body side	
7 Flange / hub assignment	Code
Adaption body	K
8 Flange size	Code
F25	F25
F30	F30
F35	F35
9 Design	Code
Round with nut for 2 keys	W
10 Diameter	Code
48 (or F25)	48
50 (for F25)	50
60 (for F25)	60
72 (for F25)	72
80 (for F25, F30)	80
98 (for F25, F30)	98
100 (for F25, F30)	100
120 (for F30)	120
160 (for F35)	160

11 Length (L)	Code
Length in increments of 100 (1000=1T0, 1100=1T1 ...)	100

Order example	1	2	3	4	5	6	7	8	9	10	11
Code	RC0	S	A	F25	W	80	K	F25	W	80	1T5
				Must be identical							

Availability - Shaft end - Round with keys (Code W)

Flange	Ø [mm]								
	48	50	60	72	80	98	100	120	160
F25	x	x	x	x	x	x	x	-	-
F30	-	-	-	-	x	x	x	x	-
F35	-	-	-	-	-	-	-	-	x

Shaft extension

Order data - Shaft end - Square

1 Type	Code
Shaft extension	RC0

2 Material	Code
Steel S235JR, 1.0037	S

Actuator side	
3 Flange / hub assignment	Code
Adaption actuator	A
4 Flange size	Code
Shaft end - Square - Round with keys	
F05 (SW 09, 11, 14)	F05
F07 (SW 11, 14, 17)	F07
F10 (SW 14, 17, 19, 22)	F10
F12 (SW 17, 19, 22, 27)	F12
F14 (SW 22, 27, 36)	F14
F16 (SW 27, 36, 46)	F16
F25 (SW 36, 46, 55)	F25
F30 (SW 46, 55, 75)	F30
5 Design	Code
Square, diagonal	D
6 Wrench size	Code
SW 09	09
SW 11	11
SW 14	14
SW 17	17
SW 19	19
SW 22	22
SW 27	27
SW 36	36
SW 46	46

Body side	
7 Flange / hub assignment	Code
Adaption body	K
8 Flange size	Code
Shaft end - Square - Round with keys	
F05 (SW 09, 11, 14)	F05
F07 (SW 11, 14, 17)	F07
F10 (SW 14, 17, 19, 22)	F10
F12 (SW 17, 19, 22, 27)	F12
F14 (SW 22, 27, 36)	F14
F16 (SW 27, 36, 46)	F16
F25 (SW 36, 46, 55)	F25
F30 (SW 46, 55, 75)	F30
9 Design	Code
Square, diagonal	D
10 Wrench size	Code
SW 09	09
SW 11	11
SW 14	14
SW 17	17
SW 19	19
SW 22	22
SW 27	27
SW 36	36
SW 46	46

11 Length (L)	Code
Length in increments of 100 (1000=1T0, 1100=1T1 ...)	100

Order example	1	2	3	4	5	6	7	8	9	10	11
Code	RC0	S	A	F10	D	22	K	F10	D	22	1T5

Must be identical

Availability - Shaft end - Square (Code D), Steel S235JR (Code S)

Flange	SW 9	SW11	SW14	SW17	SW19	SW22	SW27	SW36	SW46	SW55	SW75
F05	x	x	x	-	-	-	-	-	-	-	-
F07	-	x	x	x	-	-	-	-	-	-	-
F10	-	-	x	x	x	x	-	-	-	-	-
F12	-	-	-	x	x	x	x	-	-	-	-
F14	-	-	-	-	-	x	x	x	-	-	-
F16	-	-	-	-	-	-	x	x	x	-	-
F25	-	-	-	-	-	-	-	x	x	x	-
F30	-	-	-	-	-	-	-	-	x	x	x

Shaft extension for ball valves

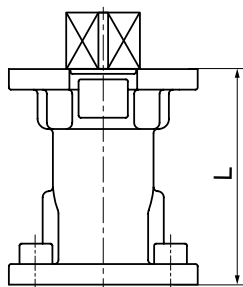

Order data - Shaft end - Stainless Steel

1 Type	Code
Shaft extension	RC0

2 Material	Code
Stainless steel	V

Actuator side	
3 Flange / hub assignment	Code
Adaption actuator	A
4 Flange size	Code
Shaft end - Square - Round with keys	
F05 (SW 09, 11, 14)	F05
F07 (SW 11, 14, 17)	F07
F10 (SW 14, 17, 19, 22)	F10
F12 (SW 17, 19, 22, 27)	F12
5 Design	Code
Square, diagonal	D
6 Wrench size	Code
SW 09	09
SW 11	11
SW 14	14
SW 17	17

Body side	
7 Flange / hub assignment	Code
Adaption body	K
8 Flange size	Code
Shaft end - Square - Round with keys	
F05 (SW 09, 11, 14)	F05
F07 (SW 11, 14, 17)	F07
F10 (SW 14, 17, 19, 22)	F10
F12 (SW 17, 19, 22, 27)	F12
9 Design	Code
Square, diagonal	D
10 Wrench size	Code
SW 09	09
SW 11	11
SW 14	14
SW 17	17

11 Length (L)	Code
61 mm (F05)	61
67 mm (F07)	67
86 mm (F10)	86
100 mm (F05, F07, F10)	100
105 mm (F12)	105
further lengths on request	

Order example	1	2	3	4	5	6	7	8	9	10	11
Code	RC0	V	A	F05	D	11	K	F05	D	11	67
							Must be identical				

Availability - Shaft end - Square (Code D), Stainless steel (Code V)				
Flange	SW 9	SW11	SW14	SW17
F04	x	x	x	-
F05	-	x	x	x
F07	-	-	x	x
F10	-	-	-	x